

FOREST MACHINE

ZAXIS 210F/210MF

A P P L I C A T I O N & A T T A C H M E N T



Model Code	ZX210F-5G	ZX210MF-5G
Engine Rated Power	125 kW (168 HP)	125 kW (168 HP)
Backhoe Bucket (ISO Heaped)	0.91 m ³	0.91 m ³
Operating Weight	22 200 kg	22 400 kg

Hitachi ZAXIS-5G is Purpose Built for Harsh Forestry Applications Including Development and Reclamation in Woods.

The Tough Engine Sustains High Uptime.

The Body and Front Are Guarded against Obstructions for Higher Durability.

Daily Maintenance and Services Are Also Simplified Even More.



Durability

Page 4-5

- Durable, reliable engine.
- Robust undercarriage for powerful travel in woods, fields and wetlands.
- Diverse reinforcements to enhance mobility.
- Exclusively reinforced guards to prevent mishap and downtime.
- Exclusively reinforced forestry-work boom and arm bear diverse external forces.



Performance

Page 6

- Reduction in fuel consumption.
- Rugged undercarriage to enhance maneuverability.



Maintenance

Page 6

- Easy-to-clean cooling system.
- Storage space.

Reinforced forestry arm

Reinforced forestry boom

Exclusive cab guards

Exclusive body guards

Durable, reliable engine

Robust fix grapple

Storage space

Exclusively reinforced undercarriage with wide 800 mm shoes



Pictured: ZX210MF-5G
Backhoe bucket is an optional.



Pictured: ZX210MF-5G



Durability

Durable, Reliable Engine

This engine has a track record showing impressive durability at countless tough job sites around the world. The engine — associated with a rugged design, a direct fuel injection system and an elaborate governor — goes simple and easy maintainability.

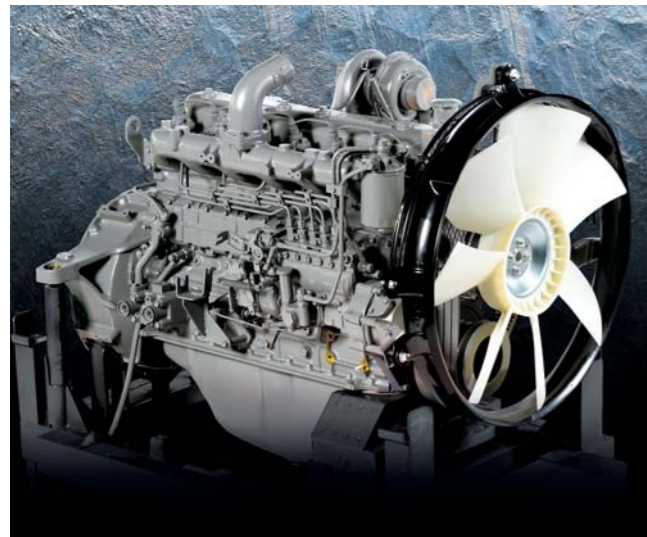

Robust Undercarriage Allows for Powerful Travel in Woods, Fields and Wetlands

Thickened Grouser-Track Links

Track links are upgraded for higher strength. Track links are 7% thicker, bushing diameter 14% greater, compared to standard ZX200-5G model.

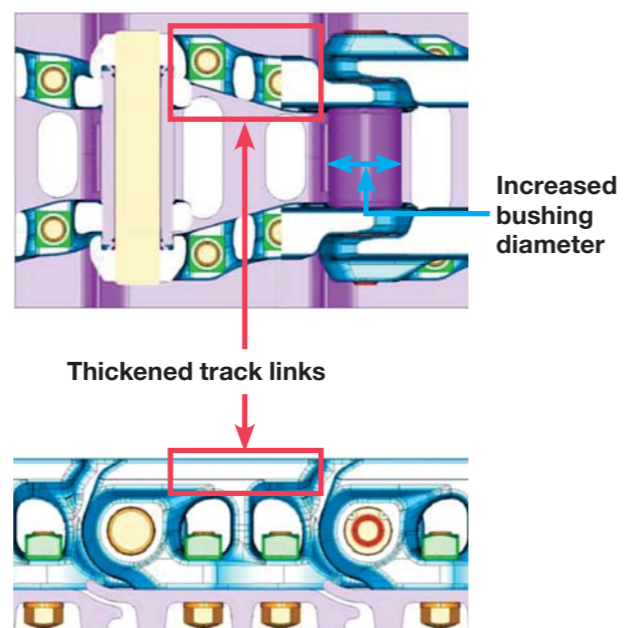

Diverse Reinforcements Enhance Mobility

The Rugged Track Frame Using Thicker Bottom Plates

Idle brackets are reinforced by thickening and structural change.

A track undercover is thickened, and bolts are fitted with guards to protect bolts from abrasion. Upper rollers are supported on both sides, and side frame tops are sloped to promote sliding-away of mud and stems.

Three track guards are provided on each track to keep track links engaged.

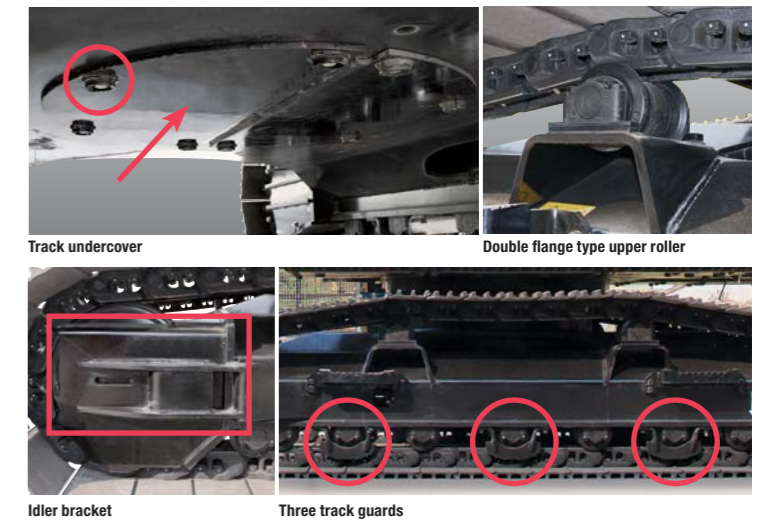

Exclusively Reinforced Guards to Prevent Mishap and Downtime

Exclusive Cab Guards

The forestry cab is fitted with a front guard, top guard and rear guard to protect the operator from obstacles. Cab guard is openable at their tops for emergency escape.

Exclusive Body Guards

The body is provided with exclusive guards on both sides to protect the radiator and hydraulic pumps, and at its top to protect the engine.



Exclusively Designed Forestry-Work Boom and Arm Bear Diverse External Forces

The boom is reinforced using thicker plates than a standard boom, and additional welds. The arm is also reinforced using thicker plates and bulkheads. These reinforcements increase the strength of the front attachment.

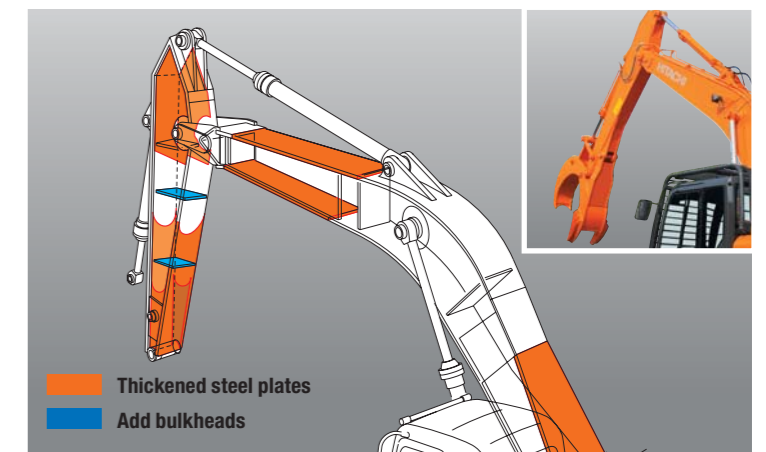

Electroplated for High Corrosion Protection

The cab and body are painted by electrodeposition coating (ED), which is immersion coating by electrolysis. This is especially effective at corrosion-prone areas, such as flat surfaces, edges and boxes, for high corrosion resistance.

The refined ED process leaves no spatter marks, as occurs with spray paint, giving a smooth mark-free surface.



Performance

5% Reduction in Fuel Consumption

The new ZAXIS consumes 5% less fuel and emits less CO₂ than a conventional ZX200, thanks to the advanced HIOS III hydraulic system and engine control system.

The Rugged Undercarriage Boasts Mobility

The new ZAXIS is fitted with wide 800 mm shoes to lower ground pressure greatly, achieving powerful travel on wetlands.

Ground pressures:

ZX210MF-5G 38 kPa

Standard ZX200-5G 44 kPa

The forest machine ZX200MF-5G has a larger ground clearance and wider track gauge to give space free from collision with stumps and other obstructions.

	ZX210MF-5G	ZX200-5G ZX210F-5G
Min. ground clearance	585 mm	450 mm
Track gauge	2 390 mm	2 200 mm



Maintenance

Easy-to-Clean Cooling System

Body guards are openable for easy maintenance and inspection.



Dust-proof indoor net can easily be removed at one touch to keep clean and reduce downtime due to clogging with insects, leaves and such. The rear of the radiator can easily be cleaned by air blowing through a one-touch open cover. The air condenser is openable for easy cleaning at its rear.

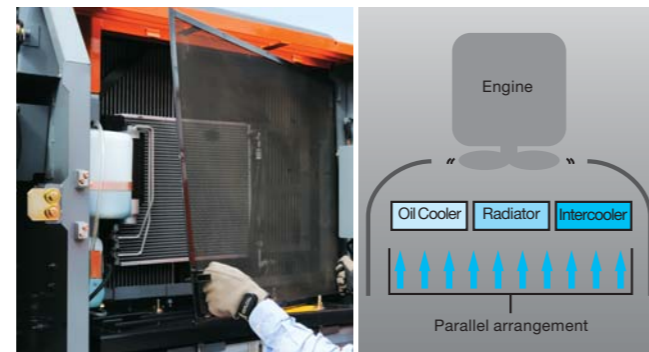

Dust-proof indoor net

Storage Space

A tool box and utility space can hold tools, parts and oils for efficient daily maintenance, helping reduce downtime.

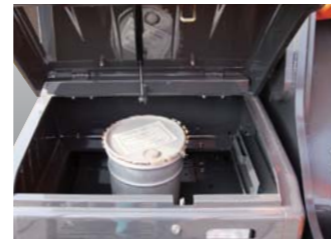

Spacious tool box



Utility space

SPECIFICATIONS

ENGINE

Model	Isuzu CC-6BG1T
Type	4-cycle water-cooled, direct injection
Aspiration	Turbocharged, intercooled
No. of cylinders	6
Rated power	
ISO 9249, net	125 kW (168 HP) at 2 100 min ⁻¹ (rpm)
SAE J1349, net	125 kW (168 HP) at 2 100 min ⁻¹ (rpm)
Maximum torque	637 Nm (65 kgfm) at 1 800 min ⁻¹ (rpm)
Piston displacement ..	6.494 L
Bore and stroke	105 mm x 125 mm
Batteries	2 x 12 V / 88 Ah

HYDRAULIC SYSTEM

Hydraulic Pumps

Main pumps	2 variable displacement axial piston pumps
Maximum oil flow ..	2 x 212 L/min
Pilot pump	1 gear pump
Maximum oil flow ..	33.6 L/min

Hydraulic Motors

Travel	2 variable displacement swash plate piston motors
Swing	1 axial piston motor

Relief Valve Settings

Implement circuit	34.3 MPa (350 kgf/cm ²)
Swing circuit	34.3 MPa (350 kgf/cm ²)
Travel circuit	34.3 MPa (350 kgf/cm ²)
Pilot circuit	3.9 MPa (40 kgf/cm ²)
Power boost	38.0 MPa (388 kgf/cm ²)

Hydraulic Cylinders

	Quantity	Bore	Rod diameter
Boom	2	120 mm	85 mm
Arm	1	135 mm	95 mm
Bucket	1	115 mm	80 mm

UPPERSTRUCTURE

Revolving Frame

D-section frame skirt for resistance to deformation.

Swing Device

Axial piston motor with planetary reduction gear is bathed in oil. Swing circle is single-row. Swing parking brake is spring-set/hydraulic-released disc type.

Swing speed	13.5 min ⁻¹ (rpm)
Swing torque	68 kNm (6 900 kgfm)

Operator's Cab

Independent spacious cab, 1 005 mm wide by 1 675 mm high, conforming to ISO* Standards.

* International Organization for Standardization

UNDERCARRIAGE

Tracks

Heat-treated connecting pins with dirt seals. Hydraulic (grease) track adjusters with shock-absorbing recoil springs.

Numbers of Rollers and Shoes on Each Side

Upper rollers	2
Lower rollers	7
Track shoes	46
Track guards	3

Travel Device

Each track driven by 2-speed axial piston motor. Parking brake is spring-set/hydraulic-released disc type. Automatic transmission system: High-Low.

Travel speeds	High : 0 to 5.5 km/h
	Low : 0 to 3.5 km/h

Maximum traction force .. 203 kN (20 700 kgf)

Gradeability

SERVICE REFILL CAPACITIES

Fuel tank	400.0 L
Engine coolant	23.0 L
Engine oil	25.0 L
Swing device	6.2 L
Travel device (each side).....	6.8 L
Hydraulic system	240.0 L
Hydraulic oil tank	135.0 L

WEIGHTS AND GROUND PRESSURE

ZX210F-5G	22 200 kg	37 kPa	0.38 (kgf/cm ²)
ZX210MF-5G	22 400 kg	38 kPa	0.39 (kgf/cm ²)

SPECIFICATIONS

DIMENSIONS ZX210F-5G/ZX210MF-5G

Unit: mm

ZX210F-5G

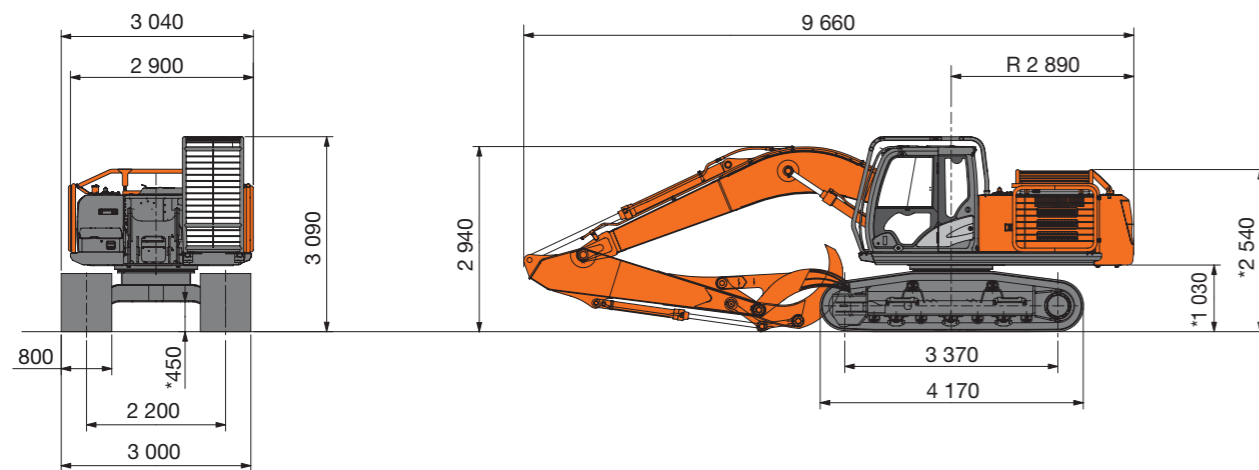

ZX210MF-5G

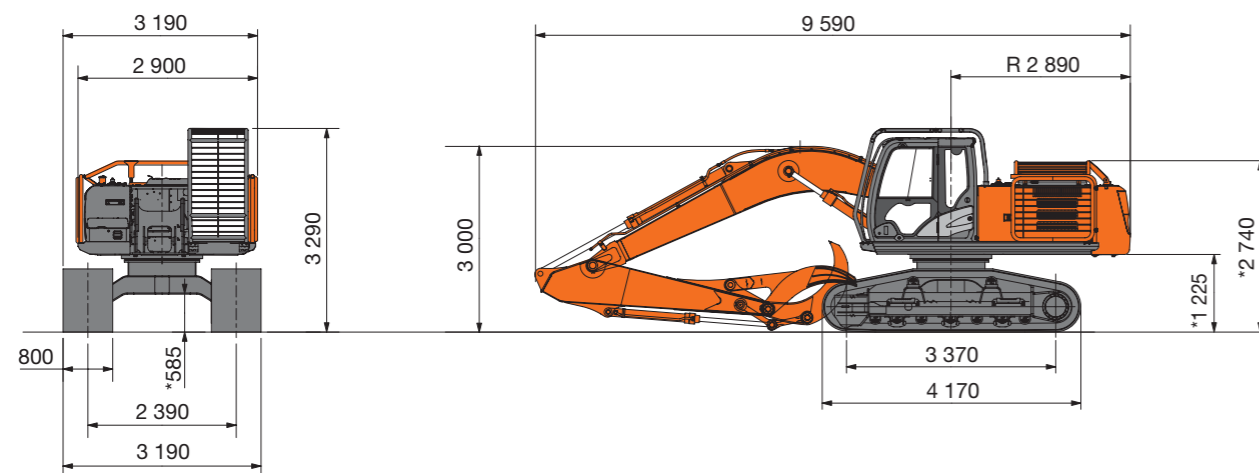

* Excluding track shoe lug

DIGGING FORCES

	ZX210F-5G	ZX210MF-5G
Arm length	2.91 m	
Bucket digging force* ISO	158 kN (16 200 kgf)	158 kN (16 200 kgf)
Arm digging force* ISO	114 kN (11 600 kgf)	114 kN (11 600 kgf)

*At power boost

WORKING RANGES ZX210F-5G/ZX210MF-5G

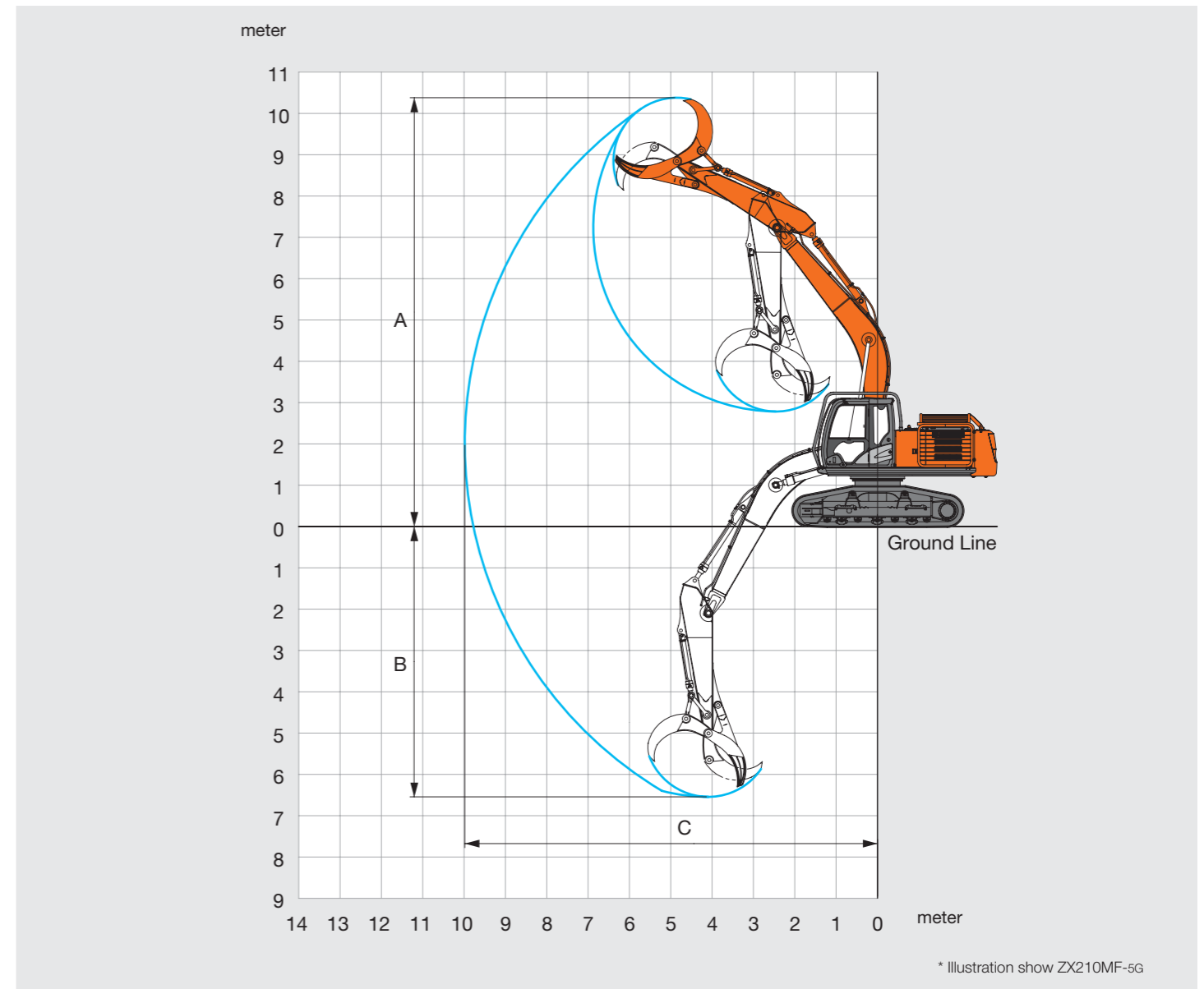

* Illustration show ZX210MF-5G

Unit: mm

	ZX210F-5G	ZX210MF-5G
Arm length	2.91 m	
A Max. Working height	10 210	10 380
B Max. Working depth	6 710	6 540
C Max. Working reach	9 980	9 980

Excluding track shoe lug

LIFTING CAPACITIES (Without Bucket)

Notes: 1. Ratings are based on ISO 10567.

2. Lifting capacity does not exceed 75% of tipping load with the machine on firm, level ground or 87% full hydraulic capacity.

3. The load point is the center-line of the bucket pivot mounting pin on the arm.

4. *Indicates load limited by hydraulic capacity.

5. 0 m = Ground.

For lifting capacities, subtract bucket and quick hitch weight from lifting capacities without bucket.

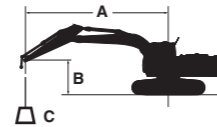

A: Load radius

B: Load point height

C: Lifting capacity

ZX210F-5G

Rating over-front Rating over-side or 360 degrees Unit : kg

Conditions	Load point height m	Load radius m										At max. reach		
		1.5		3.0		4.5		6.0		7.5		meter		
		Rating over-front	Rating over-side or 360 degrees	Rating over-front	Rating over-side or 360 degrees	Rating over-front	Rating over-side or 360 degrees	Rating over-front	Rating over-side or 360 degrees	Rating over-front	Rating over-side or 360 degrees			
5.68 m H-boom 2.91 m arm Counterweight 4 200 kg Shoe 800 mm	6.0											*3 950	3 560	7.32
	4.5					*6 490	*6 490	*5 650	4 820	5 000	3 380	*3 890	3 020	8.01
	3.0					*8 380	6 970	*6 510	4 580	4 890	3 270	*4 000	2 750	8.37
	1.5					*10 100	6 470	6 640	4 340	4 760	3 160	3 980	2 640	8.45
	0 (Ground)			*4 750	*4 750	10 060	6 200	6 450	4 170	4 660	3 070	4 070	2 690	8.25
	-1.5	*5 390	*5 390	*9 010	*9 010	9 970	6 130	6 370	4 100	4 640	3 040	4 430	2 920	7.76
	-3.0	*9 880	*9 880	*14 200	11 820	10 050	6 190	6 410	4 140			5 270	3 460	6.90
	-4.5			*11 070	*11 070	*7 970	6 410					*6 110	4 850	5.52

ZX210MF-5G

Rating over-front Rating over-side or 360 degrees Unit : kg

Conditions	Load point height m	Load radius m										At max. reach			
		1.5		3.0		4.5		6.0		7.5		meter			
		Rating over-front	Rating over-side or 360 degrees	Rating over-front	Rating over-side or 360 degrees	Rating over-front	Rating over-side or 360 degrees	Rating over-front	Rating over-side or 360 degrees	Rating over-front	Rating over-side or 360 degrees				
5.68 m H-boom 2.91 m arm Counterweight 4 200 kg Shoe 800 mm	6.0							*5 150	*5 150	5 260	5 030	3 700	*3 930	3 800	7.43
	4.5					*6 710	*6 710	*5 750	5 260	5 030	3 700	*3 900	3 270	8.07	
	3.0					*8 640	7 640	*6 630	5 010	4 910	3 590	*4 030	3 000	8.39	
	1.5					*10 270	7 150	6 670	4 770	4 790	3 470	4 020	2 920	8.44	
	0 (Ground)			*5 260	*5 260	10 130	6 900	6 490	4 610	4 700	3 390	4 140	3 000	8.20	
	-1.5	*5 960	*5 960	*9 660	*9 660	10 070	6 850	6 430	4 550	4 690	3 370	4 550	3 280	7.67	
	-3.0	*10 530	*10 530	*13 880	13 520	*9 870	6 930	6 490	4 600			5 500	3 950	6.76	
	-4.5			*10 490	*10 490	*7 520	7 190					*6 070	5 750	5.27	

EQUIPMENT

Standard and optional equipment may vary by country, so please consult your Hitachi dealer for details.

● : Standard equipment

○ : Optional equipment

	ZX210F-5G	ZX210MF-5G
ENGINE		
Air cleaner double filters	●	●
Auto idle system	●	●
Cartridge-type engine oil filter	●	●
Cartridge-type fuel main filter	●	●
Dry-type air filter with evacuator valve (with air filter restriction indicator)	●	●
Engine warm-up device	●	●
Side by side cooling unit	●	●
Fan guard	●	●
Water separator	●	●
Dust-Proof indoor net	●	●
Radiator reserve tank	●	●
50A alternator	●	●

	ZX210F-5G	ZX210MF-5G
HYDRAULIC SYSTEM		
Auto power lift	●	●
Control valve with main relief valve	●	●
Full-flow filter	●	●
Pilot filter	●	●
Power boost	●	●
Suction filter	●	●
One extra port for control valve	●	●
Work mode selector	●	●

	ZX210F-5G	ZX210MF-5G
CAB		
All-weather sound suppressed steel cab	●	●
AM-FM radio with 2 speakers	●	●
Ashtray	●	●
Auto control air conditioner	○	○
Cab (Center pillar reinforced structure)	●	●
Drink holder	●	●
Drink holder with hot & cool	○	○
Electric double horn	●	●
Engine shut-off lever	●	●
Evacuation hammer	●	●
Floor mat	●	●
Footrest	●	●
Front window washer	●	●
Front window on upper, lower and left side can be opened	●	●
Cab guard	●	●
Glove compartment	●	●
Hot & cool box	○	○

Intermittent windshield wipers	●	●
Key cylinder light	●	●
LED room light with door courtesy	●	●
OPG top guard Level I (ISO10262) compliant cab	●	●
Pilot control shut-off lever	●	●
Rear tray	●	●
Retractable seat belt	●	●
Rubber radio antenna	●	●
Seat: Fabric seat	●	●
Seat adjustment part: backrest, armrest, height and angle, slide forward/back	●	●
Short wrist control levers	●	●
4 fluid-filled elastic mounts	●	●
24 V cigarette lighter	●	●

	ZX210F-5G	ZX210MF-5G
MONITOR SYSTEM		
Alarm buzzers: overheat, engine oil pressure, overload	●	●
Alarm: overheat, engine warning engine oil pressure, alternator, minimum fuel level, hydraulic filter restriction, air filter restriction, work mode, overload, etc	●	●
Display of meters:work mode, auto-idle, glow, operating conditions, etc	●	●
32 languages selection	●	●

	ZX210F-5G	ZX210MF-5G
LIGHTS		
2 working lights	●	●

	ZX210F-5G	ZX210MF-5G
UPPERSTRUCTURE		
Fuel level float	●	●
Hydraulic oil level gauge	●	●
Tropical cover	●	●
Side bumper & cab guard bracket	●	●
Body guard (Engine, Fuel tank, door)	●	●
Rear view mirror (left side)	●	●
Swing parking brake	●	●
Tool box	●	●
6.0 mm reinforced undercover	●	●
Utility space	●	●
4 200 kg counterweight	●	●
2x88 Ah batteries	●	●

	ZX210F-5G	ZX210MF-5G
UNDERCARRIAGE		
Reinforced track frame	●	●
High & Width track	—	●
Bolt-on sprocket	●	●
Reinforced track links with pin seals	●	●
Reinforced idler bracket	●	●
Reinforced travel motor covers	●	●
Travel parking brake	●	●
Reinforced track undercover	●	●
Hydraulic track adjuster	●	●
Lower rollers	●	●
Reinforced upper rollers	●	●
3 track guards	●	●
4 tie down hooks	●	●
800 mm reinforced triple grouser shoes	●	●
Reinforced side step (Bolt on type)	●	●

	ZX210F-5G	ZX210MF-5G
FRONT ATTACHMENTS		
Centralized lubrication system	●	●
Dirt seal on all bucket pins	●	●
Flanged pin	●	●
HN bushing	●	●
Reinforced resin thrust plate	●	●
Link A	●	●
Link B	●	●
Fixed grapple	●	●
0.91 m³ bucket (ISO heaped)	○	○
0.91 m³ horn bucket (ISO heaped)	○	○
2.91 m reinforced arm (with grapple bracket)	●	●
5.68 m H-boom	●	●

	ZX210F-5G	ZX210MF-5G
MISCELLANEOUS		
Lockable fuel refilling cap	●	●
Lockable machine covers	●	●
Onboard information controller	●	●
Skid-resistant tapes, plates and handrails	●	●
Standard tool kit	●	●
Travel direction mark on track frame	●	●
Global e-Service	●	●



Built on the foundation of superb technological capabilities, Hitachi Construction Machinery is committed to providing leading-edge solutions and services to contribute as a reliable partner to the business of customers worldwide.

Hitachi Environmental Vision 2025

The Hitachi Group released the Environmental Vision 2025 to curb annual carbon dioxide emissions. The Group is committed to global production while reducing environmental impact in life cycles of all products, and realizing a sustainable society by tackling three goals — prevention of global warming, conservation of resources, and preservation of ecosystem.

Reducing Environmental Impact by New ZAXIS

Hitachi makes a green way to cut carbon emissions for global warming prevention according to LCA*. New ZAXIS utilizes lots of technological advances, including the new ECO mode, and Isochronous Control. Hitachi has long been committed to recycling of components, such as aluminum parts in radiators and oil cooler. Resin parts are marked for recycling.

*Life Cycle Assessment – ISO 14040

These specifications are subject to change without notice.

Illustrations and photos show the standard models, and may or may not include optional equipment, accessories, and all standard equipment with some differences in color and features.

Before use, read and understand the Operator's Manual for proper operation.