

ZAXIS-5G series

HITACHI

Reliable solutions

# ZAXIS470



ConSite OIL

Consolidated Solution for Construction Sites

Oil monitoring sensor to  
maximize machine life cycle

## HYDRAULIC EXCAVATOR

Model Code : ZX470LC-5G / ZX470LCH-5G

Engine Rated Power : 235 kW (315 HP)

Operating Weight : ZX470LC-5G : 47 000 kg / ZX470LCH-5G : 47 900 kg

Backhoe Bucket : ISO Heaped : 1.15 - 2.65 m<sup>3</sup>

# WALK AROUND



## Reduction in Fuel Consumption

Upgraded HIOS IIIB hydraulic system, ECO mode, and auto-idle feature ensure machine conserves fuel more efficient to maintain longer performance in the field.

## Improved Arm Controllability

For level front movement luffing and crowding. Newly adopted variable orifice of the swing circuit ensure hydraulic oil is effectively allocated and reduces pressure loss.

## Increased Durability

Internal and complete welding prevents cracking and extends service life of the welded steel plate joints. Side frame of the arm is thickened to enhanced durability.

## Smooth Operation

Enhanced power-boosting pressure function to increase basic performance.

## Focused on Safety

Enforced cab is fitted with front window lower protection nets and multiple handrails to ensure operator safety.

## Powerful Non-Common Rail Type Engine

Quiet running, fuel-efficient and powerful Tier 2 / Stage II engine for generous arm force, dig force and lift capacity.

## Ultimate Comfort

Deluxe operator cab is well-ventilated with controls within easy reach of the operator. Cab also features luxury cloth seat, armrests and plenty of legroom.

## Quick & Easy Service Access

Maintenance is convenient with easily-located inspection points that are accessible from ground level.

## Rock-Solid, Durable Front Attachment

Improved heavy-duty boom and arm has increased strength compared to the conventional model. The ZX470LC-5G / ZX470LCH-5G is able to operate at tough job sites.

## Enhanced basic performance

Swing torque, boom lifting capacities, and traction, arm digging and bucket digging forces on the ZX470LC-5G / ZX470LCH-5G have all been increased. With these upgraded features, the ZX470LC-5G / ZX470LCH-5G offers better performance than before with

**8%** increased in swing torque

**3%** increased in traction force

**3%** increased in boom lifting capacities

**3%** increased in arm digging force\*

**3%** increased in bucket digging force\*

*(compared to the conventional ZX450-3 / ZX450-3F family)*

*\*At power boost*

*\*\* PWR mode vs. conventional mode's P mode*

## Reduction in fuel consumption

Upgraded HIOS IIIB hydraulic system and engine control system allows the new ZX470LC-5G / ZX470LCH-5G to reduce fuel consumption by 8%\*\* in comparison to the conventional models. Auto-idle mode automatically reduces engine speed when hydraulics aren't in use to reduce fuel usage.

Additionally, new ECO mode feature can further cut fuel consumption by 9% compared to PWR mode without sacrificing digging force.

**9%** ECO mode fuel saving

**8%** PWR mode fuel saving

# Simply Easy Maintenance

Less downtime with easier maintenance

The ZX470LC-5G / ZX470LCH-5G is easy and convenient to maintain. All filters and inspection points are systematically grouped and servicing is easier and less messy with vertical spin-on fuel, hydraulic and engine oil filters. Now with the newly added ConSite OIL monitoring and analysis system, you can detect issues quicker to minimise machine downtime.

## Easy access to inspection points

Inspection points are centrally-grouped inside left and right covers to allow easy, intuitive routine maintenance. Drain water from the fuel tank or replace filters simply by opening a lid. The inspection points can be accessed from ground level for convenient servicing.

## Easy access to upper structure

Access the engine easily via sidewalk and 3-step ladder. The sidewalk is wide, designed with slip-resistant plates and fitted with multiple handrails for human safety.

## Fast lubrication

Centralised greasing points on the arm and boom let you lubricate front parts with ease. An optional electric grease gun with hose-reel or an auto-grease lubricator is also available for faster greasing / lubrication.



Inspection on the easily accessible and removable air cleaner.



Inspection points on the right cover



Inspection points on the left cover

## Key features

- Low-life cycle cost
- 705L Large Capacity fuel tank
- Easy replacement of the air conditioner filters
- Easy replacement of water separator
- Easy to drain from fuel tank
- Spacious sidewalk for accessing engine
- 3-Step Ladder
- Multiple handrails

# Work In Comfort & Safety

Comfortable, safe operator cab

## Safety first

The OPG cab is reinforced with steel tubing and front window lower protection net to ensure operator safety from falling objects. For added security, the engine is password-lockable via the 10-key panel. Installed rearview camera always displays the view behind the machine.

## 6-point secure mounting

The cab shell is bolted to the frame at 6 points using liquid-filled rubber bearings to absorb vibrations and improve resistance to fatigue, ensuring safety and comfort for the operator.



## Deluxe operator seat

The spacious operator cab features a luxury cloth seat, fitted with a headrest and armrests for working in comfort. The seat is fully adjustable, sliding and reclining to suit operator's size and preferences. For extra leg space, the seat can slide rearward by 40 mm more and can be fitted with air suspension and a heat pad (optional).



## Key features

- 7-inch high-resolution, multi-function color monitor
- Password-lockable engine via 10-key panel
- Openable overhead window for ventilation
- Spacious leg space
- New LED room light
- Low vibration cab with fluid-filled rubber mounts
- Large utility space
- Drink holder & hot and cool box

# Engineered For Heavier Duty Work

Maneuver and take on rugged terrain and sites

Work in confidence knowing the new ZX470LC-5G / ZX470LCH-5G is built to take on difficult worksapes. Improved boom, arm and mainframe are strengthened to endure relentless hours of work and the fortified undercarriage with thicker guard plates supports machine travel in woods, fields, wetlands and rock with unshakable stability.

## High-pressure power engine

Tier 2/Stage II emissions engine with direct fuel injection system and elaborate governor provides outstanding engine performance. Proven to withstand the toughest job sites around the world with its rugged design and durability.

## Rock-solid, durable front attachment

The new ZX470LC-5G / ZX470LCH-5G offers more rock-solid durability with thicker plates, single-sheet mainframe, box-section track frames and large, double-seal swing bearings.

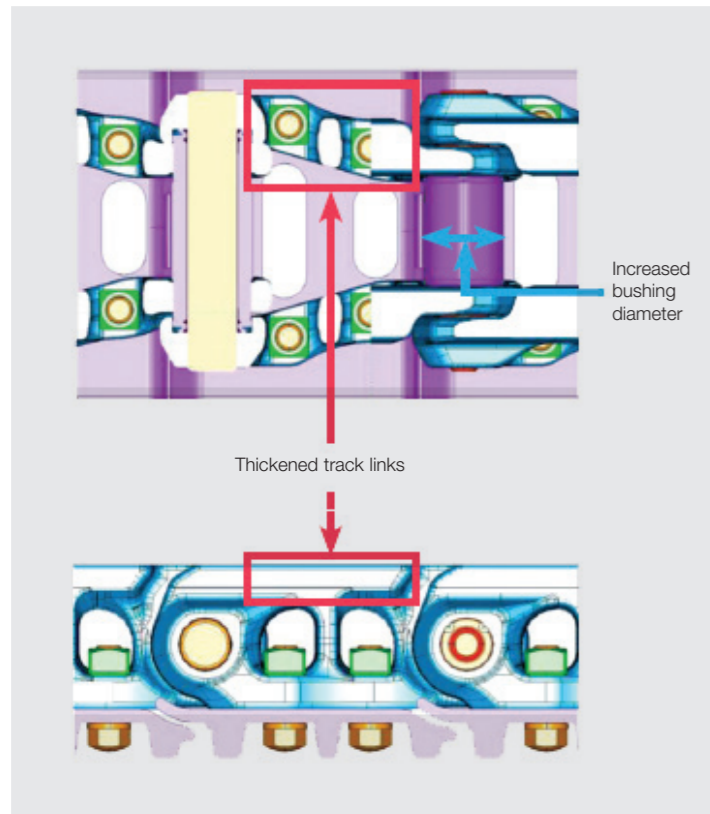

### H-Boom

Boom has been reinforced with complete welding and internal welding to prevent cracking of the internal joints during continuous high-load operations. Plate thickness has also been increased and fitted with anti-wear plate to enhance boom durability. The single-plate structure of the boom end side plate.

### H-Arm

The arm has been strengthened with thicker side frame to increase durability. Arm bump anti-wear plate prevents the arm from deforming when digging and loading limestone and crushed rock.

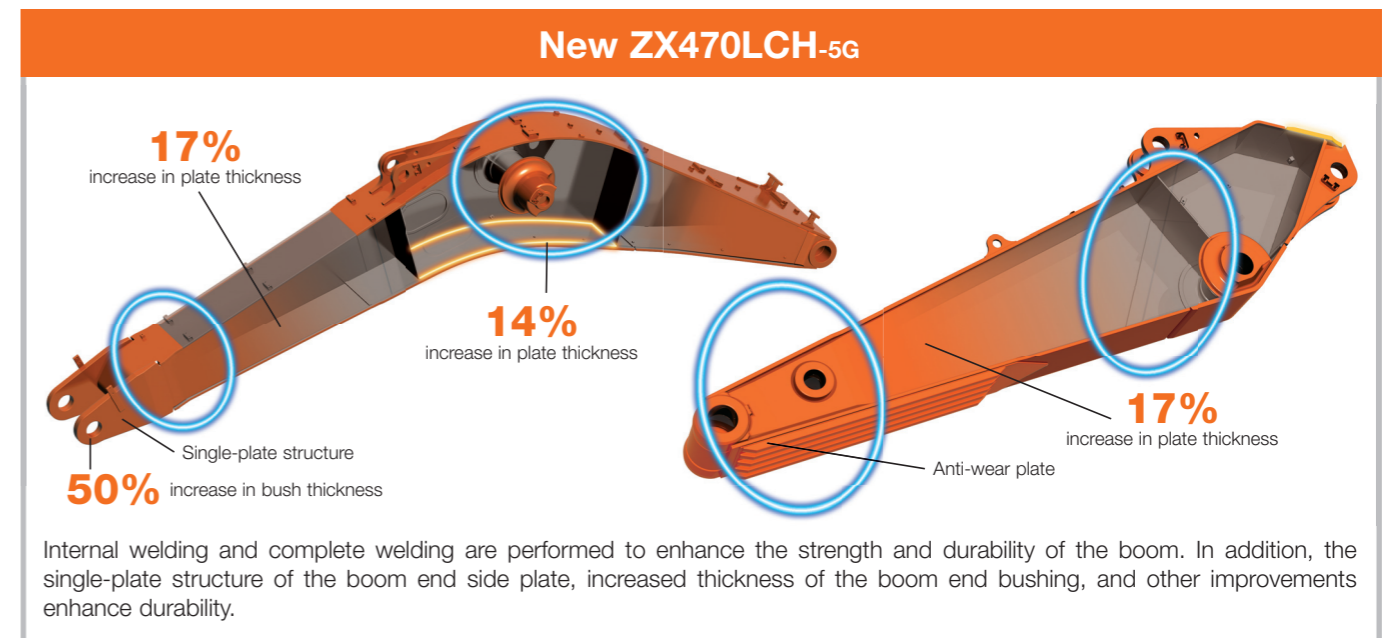
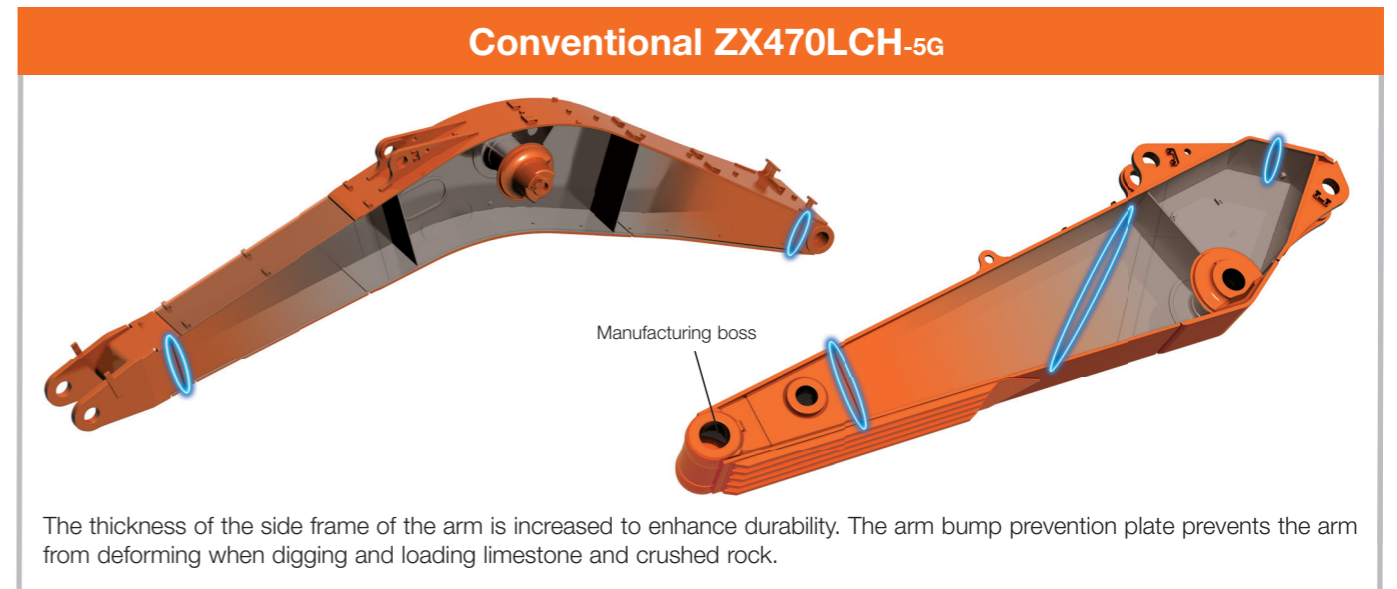

Complete welding Internal welding

## Key features

- 235 kW (315 HP) engine
- Damage prevention plate and 5 square bars
- Boom hose protector
- Reinforced upper structure frame with proven D-section skirt
- More complete welding parts on front attachment

Hitachi's state-of-the-art complete welding technique grants your machine robust durability to take on high-volume work without cracking.

### Benefits of complete welding

- Higher tensile strength compared to traditional welding technique
- Reduced burn-through of parts for extended service life
- Easy, effortless and economical maintenance

# Easy-To-Use Attachments

Maximise your investment & productivity

The upgraded ZX470LC-5G / ZX470LCH-5G is a high-durability, heavy-duty machine with generous arm force, dig force and lift capacity. Fitted with a quiet-running, fuel-efficient Tier 2 / Stage II emissions engine and 3 work modes - High Productivity, Power and Economy – experience great site productivity while keeping costs low.

## Speed and precision with HIOS\*IIIB hydraulics

Operating speed of the arm and boom is swift and precise thanks to the HIOS\*IIIB hydraulic system, developed by industry-led hydraulic technologies.

## Total arm control

The boom regenerative circuit utilizes boom weight and the newly adopted variable orifice of the swing circuit for exceptional flow, swing torque and lift capacity.

## Easy-to-use attachments

Easily change over valves, adjust extra circuit flow and check settings from the multi-function monitor next to the operator seat. What's more, 11 jobs, including flow rate settings, can be easily selected by their identified names.



Photo for illustration purpose only.

\*Human & Intelligent Operation System

## Key features

- 8%\* reduction in fuel consumption
- 9% less fuel consumption in ECO mode (vs PWR mode)
- Increased operating speed with less fuel consumption
- Improved arm controllability

# Hitachi Service Support

Helping you protect your investment

## Extended warranty and service contracts

Every new Hitachi model is covered by a full manufacturer's warranty. However, your ZAXIS excavator may require extra protection due to severe working conditions or to minimise equipment repair costs. To meet these demands, our dealers offer the option of a unique extended warranty programme (HELP – Hitachi Extended Life Program) and comprehensive service contracts – the most effective way to optimize the performance of your new ZAXIS excavator.

## Technical support

The professional and highly trained Hitachi service team combine the global expertise and knowledge of Hitachi with your local language and culture. We take a proactive approach towards customer service by continuously training our dealer personnel, so that the available global knowledge is passed on to each individual technician in our dealer network.

## ConSite Pocket

Remote monitoring at your fingertips\*

Turn your smartphone into a management centre for all your Hitachi machines. The ConSite Pocket app gives you the ability to monitor all your Hitachi machines from the palm of your hand. Connect your machines to the app to receive status reports and alerts directly to your smartphone. Keep track of your machine's health out in the field and stay notified with push notifications. Receive insights on your fleet such as daily working hours and fuel consumption - all at your fingertips with the ConSite Pocket app.

The ConSite Pocket app is also connected to your local Hitachi dealer, allowing you to arrange support in no time if problems arise. Work with better peace of mind knowing that ConSite Pocket helps you stay on top of technical issues.

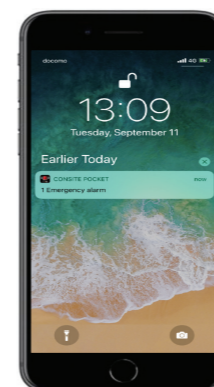

Push notification



### EASY TO USE APP

Featuring a user-friendly interface and intuitive design, the ConSite Pocket app allows you to access its great features at a glance. Navigate and manage your machines easily with the implemented Hitachi Global e-Service machine condition management system.

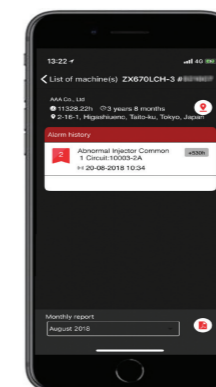

Emergency alarm



### REAL-TIME ALERTS

Push notifications alert you in real time when issues are detected in your machine. The alerts will give you an accurate description of the issue along with manufacturer recommendations on steps you can take to troubleshoot the problem.

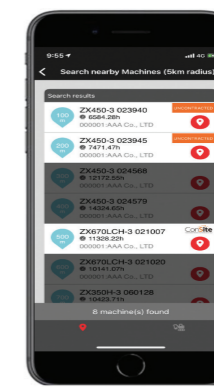

Machine finder



### MACHINE FINDER

Keep track of your multiple machines wherever they may be in the field. Utilizing GPS tracking technology, this feature allows you to select any machine and know its exact location on the map with a drop pin.

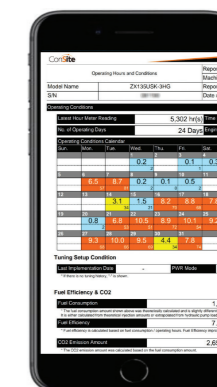

Monthly report



### DOWNLOAD REPORTS

Receive monthly reports and performance data of your machine straight on your smartphone anytime and from anywhere. Compare reports from previous months, keep up to date with your machine's health and access your machine's operational hours at the touch of a button.

\* Please consult to Hitachi authorize dealer for more ConSite Pocket information & its availability in respective country.

# ConSite OIL

Intelligent oil monitoring & analysis system

**Industry first\* monitoring solution on a continuous basis for 24/7 by oil monitoring sensors**



\*The ConSite OIL monitoring system is the latest technological aid in Advanced Preventative Maintenance for machinery. It is fitted in Hitachi machines with onboard oil monitoring system.

## What is ConSite OIL?

Proper oil management is vital for hydraulic system and engine health. Like a blood test for the human body, oil analysis helps identify your machine's condition for possible contamination or deteriorations. Key properties the oil monitoring sensors watch out for:

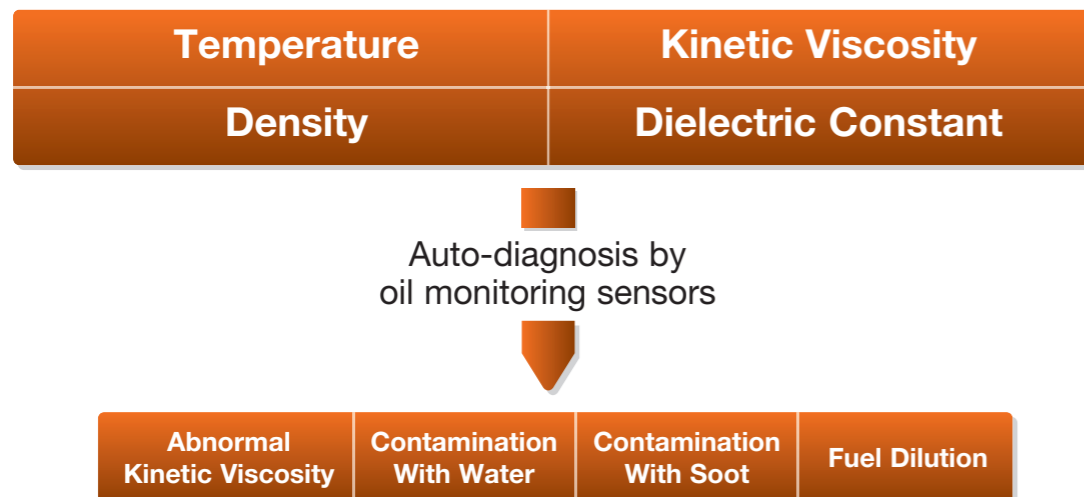

## Key features

- Automatic daily-morning monitoring alert
- Quick-time alerts once the ideal oil temperature is reached
- 24/7 oil monitoring & auto-diagnostics while machine is running
- Reduced machine running costs
- Reduced machine downtime & faster countermeasures
- Longer machine life and a sense of security

With ConSite OIL monitoring and analysis system, oil can be monitored 24/7 with minute changes noticed. This allows immediate diagnosis of potential problems while extending machine life exponentially.

## In case of detection of sudden change in oil condition

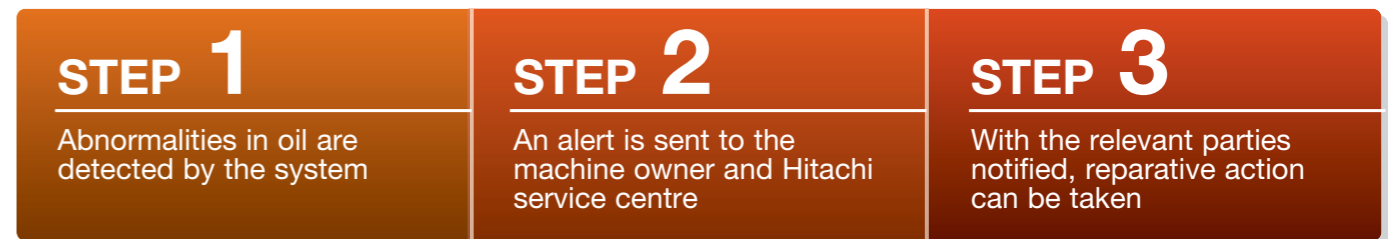

## With ConSite OIL...

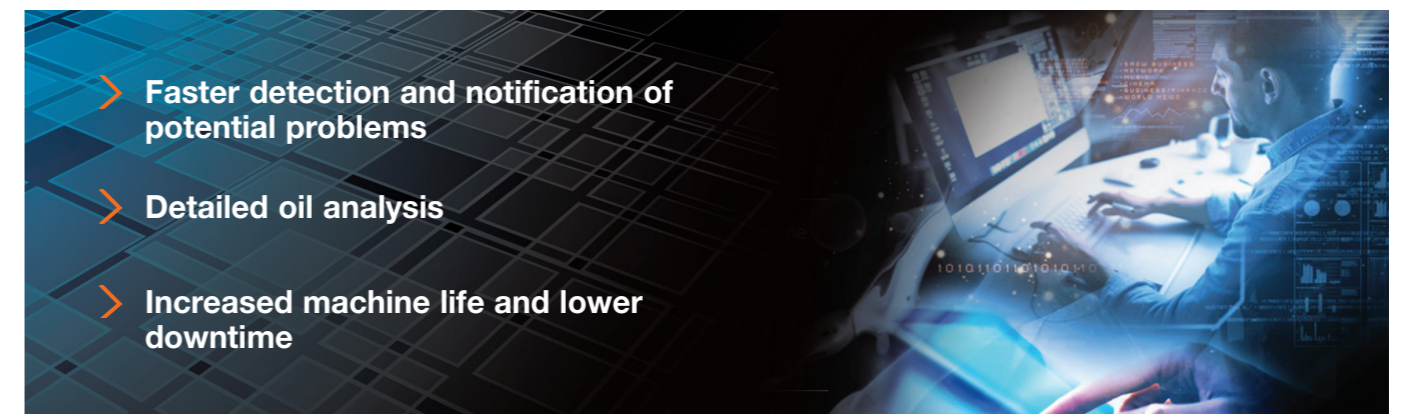

## Without ConSite OIL...

Absence of preventative maintenance via oil condition monitoring and analysis will cause:

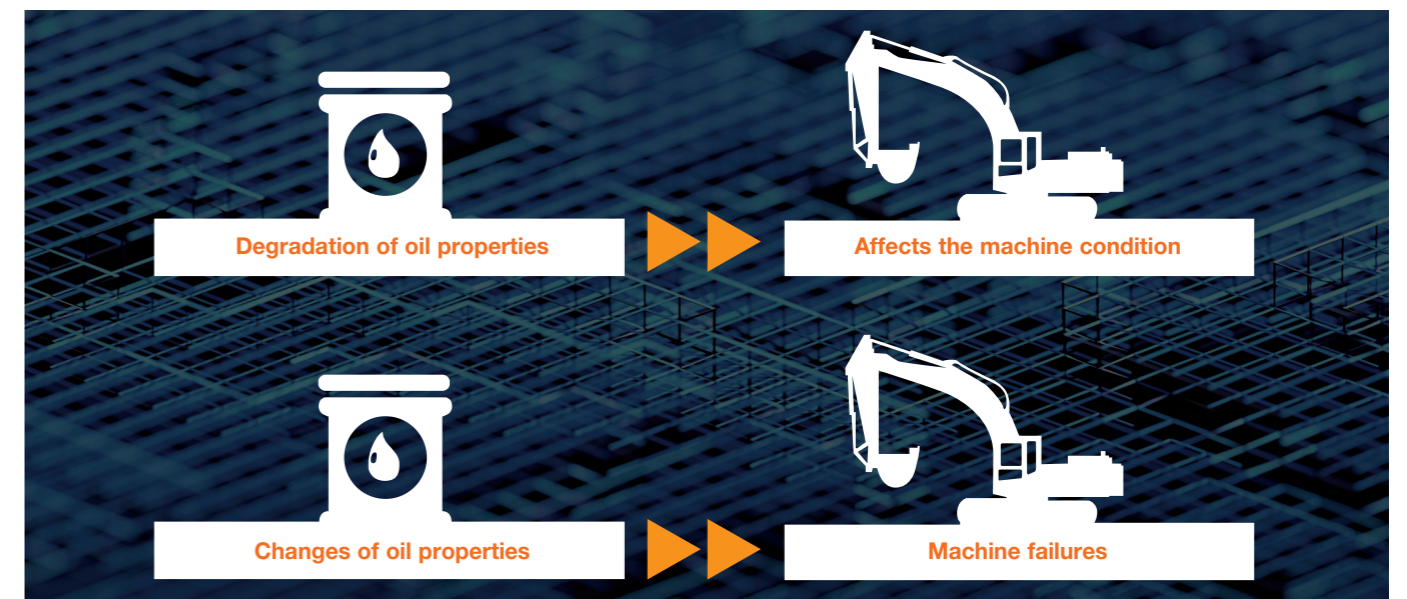

# Hitachi Genuine Parts

Design to perform. Build to last.

## Values of Hitachi construction machinery

The lineup of Hitachi Construction Machinery machines features high environmental performances and utilizations.

Machine performances can be maximized by the proficient techniques of the service and reliable quality of Hitachi genuine parts.

Hitachi genuine parts ensure three values:

- Provide performance in harsh operating environments
- Reduce total operation cost and extend the life of machines
- Reduce environmental load

See the various values that are created by unifying these three elements with your eyes and hands for yourself.



### High Accuracy Mechanism

Machine design that is high-performing in dimensional environment and work aspects



### Service Maintenance

Experts in machine structures maximize machine performance



### Hitachi Genuine Parts

Vital parts to maximize machine performance

## Environment for optimal machine performance

## SPECIFICATIONS

### ENGINE

Model .....	Isuzu AA-6WG1TQA
Type .....	4-cycle water-cooled, direct injection
Aspiration .....	Turbocharged
No. of cylinders .....	6
Rated power	
ISO 14396 .....	H/P mode:
	235 kW (315 HP) at 1 800 min <sup>-1</sup> (rpm)
Maximum torque .....	1 275 Nm (130 kgf m) at 1 500 min <sup>-1</sup> (rpm)
Piston displacement ..	15.681 L
Bore and stroke .....	147 mm x 154 mm
Batteries .....	2 x 12 V / 170 Ah

### HYDRAULIC SYSTEM

#### Hydraulic Pumps

Main pumps .....	2 variable displacement axial piston pumps
Maximum oil flow ..	2 x 360 L/min
Pilot pump .....	1 gear pump
Maximum oil flow ..	30 L/min

#### Hydraulic Motors

Travel .....	2 axial piston motors with parking brake
Swing .....	2 axial piston motors

#### Relief Valve Settings

Implement circuit .....	31.9 MPa (325 kgf/cm <sup>2</sup> )
Swing circuit .....	28.4 MPa (290 kgf/cm <sup>2</sup> )
Travel circuit .....	35.3 MPa (360 kgf/cm <sup>2</sup> )
Pilot circuit .....	3.9 MPa (40 kgf/cm <sup>2</sup> )
Power boost .....	35.3 MPa (360 kgf/cm <sup>2</sup> )

#### Hydraulic Cylinders

	Quantity	Bore	Rod diameter
Boom	2	170 mm	115 mm
Arm	1	190 mm	130 mm
Bucket	1	170 mm	120 mm

### UPPERSTRUCTURE

#### Revolving Frame

D-section frame for resistance to deformation.

#### Swing Device

Axial piston motor with planetary reduction gear is bathed in oil. Swing parking brake is spring-set/hydraulic-released disc type.

Swing speed .....	9.0 min <sup>-1</sup> (rpm)
-------------------	-----------------------------

#### Operator's Cab

##### ZX470LC-5G / ZX470LCH-5G (H/R cab):

Independent spacious cab, 1 025 mm wide by 1 817 mm high. The OPG top guard fitted Level II conforms to the related requirements of the International Organization for Standardization (ISO) 10262.

### UNDERCARRIAGE

#### Tracks

Track shoes with triple grousers made of induction-hardened rolled alloy. Heat-treated connecting pins with dirt seals. Hydraulic (grease) track adjusters with shock-absorbing recoil springs.

#### Numbers of Rollers and Shoes on Each Side

Upper rollers .....	2
Lower rollers .....	9: ZX470LC-5G / ZX470LCH-5G
Track shoes .....	53: ZX470LC-5G / ZX470LCH-5G
Idler track guard .....	1: ZX470LC-5G
Track guard .....	2: ZX470LC-5G
Full track guard :	ZX470LCH-5G

#### Travel Device

Each track driven by axial piston motor through reduction gear for counter rotation of the tracks. Parking brake is spring-set/hydraulic-released disc type.

Automatic transmission system: High-Low.

Travel speeds .....	High : 0 to 5.1 km/h
	Low : 0 to 3.8 km/h

Maximum traction force ..	329 kN (33 600 kgf)
---------------------------	---------------------

Gradeability .....	70% (35 degree) continuous
--------------------	----------------------------

### SERVICE REFILL CAPACITIES

Fuel tank .....	705.0 L
Engine coolant .....	61.0 L
Engine oil .....	55.0 L
Swing device (each side) .....	6.5 L
Travel device (each side) .....	11.0 L
Hydraulic system .....	510.0 L
Hydraulic oil tank .....	310.0 L

# SPECIFICATIONS

## WEIGHTS AND GROUND PRESSURE

### Operating Weight and Ground Pressure

Shoe type	Shoe width	Boom type	Arm type	ZX470LC-5G		ZX470LCH-5G	
				kg	kPa (kgf/cm <sup>2</sup> )	kg	kPa (kgf/cm <sup>2</sup> )
Triple or double grouser	600 mm	7.0 m H	3.4 m H	47 000	80 (0.81)	47 900	81 (0.83)
		Bucket capacity		2.1 m <sup>3</sup>		1.9 m <sup>3</sup> Rock bucket	
		6.3 m BE	2.5 m BE	47 500	80 (0.82)	48 300	82 (0.84)
Triple grouser	750 mm	Bucket capacity		2.65 m <sup>3</sup>		2.5 m <sup>3</sup> Rock bucket	
		7.0 m H	3.4 m H	47 800	65 (0.66)	-	-
		Bucket capacity		2.1 m <sup>3</sup>		-	-
		6.3 m BE	2.5 m BE	48 200	65 (0.67)	-	-
Bucket capacity		2.65 m <sup>3</sup>		-	-	-	

## BUCKET LIST

### ZX470LC-5G

Capacity	Width		No. of teeth	Weight	Recommendation				
	ISO heaped	Without side cutters			With side cutters	6.3 m BE-boom		7.0 m H-boom	
						2.5 m BE-arm	2.9 m BE-arm	2.9 m BE-arm	3.4 m H-arm
1.15 m <sup>3</sup>	1 100 mm	1 210 mm	5	1 070 kg	x	x	x	x	
1.40 m <sup>3</sup>	1 280 mm	1 410 mm	5	1 170 kg	x	x	x	x	
1.60 m <sup>3</sup>	1 220 mm	1 360 mm	5	1 480 kg	-	-	○	○	
1.90 m <sup>3</sup>	1 400 mm	1 540 mm	5	1 590 kg	-	-	○	○	
2.10 m <sup>3</sup>	1 490 mm	1 630 mm	5	1 650 kg	-	-	○	○	
2.30 m <sup>3</sup>	1 520 mm	1 660 mm	5	1 800 kg	○	○	○	○	
2.50 m <sup>3</sup>	1 630 mm	1 770 mm	5	1 870 kg	○	○	-	-	
2.65 m <sup>3</sup>	1 720 mm	1 860 mm	5	1 930 kg	○	○	-	-	
Applicable shoe type					600 mm Triple grouser or double grouser 750 mm Triple grouser				

### ZX470LCH-5G

Capacity	Width		No. of teeth	Weight	Recommendation				
	ISO heaped	Without side cutters			With side cutters	ZX470LCH-5G			
						6.3 m BE-boom		7.0 m H-boom	
		2.5 m BE-arm	2.9 m BE-arm	2.9 m BE-arm	3.4 m H-arm				
*1 1.90 m <sup>3</sup>	1 480 mm	1 500 mm	5	2 070 kg	●	●	●	●	
*1 2.10 m <sup>3</sup>	1 560 mm	1 580 mm	5	2 170 kg	●	●	●	●	
*1 2.30 m <sup>3</sup>	1 680 mm	1 700 mm	5	2 260 kg	●	●	-	-	
*1 2.50 m <sup>3</sup>	1 800 mm	1 820 mm	5	2 360 kg	●	●	-	-	
*2 1.30 m <sup>3</sup>	1 170 mm	-	3	2 330 kg	●	●	●	●	
One-point ripper					●	●	●	●	
Applicable shoe type					600 mm Triple grouser or double grouser				

\*1 Rock bucket  
\*2 Ripper bucket

- Heavy-duty service
- Suitable for material with density of 1 600 kg / m<sup>3</sup> or less
- ◎ Suitable for material with density of 1 800 kg / m<sup>3</sup> or less
- Not applicable
- x Can't be installed

## WORKING RANGES

### ZX470LC-5G

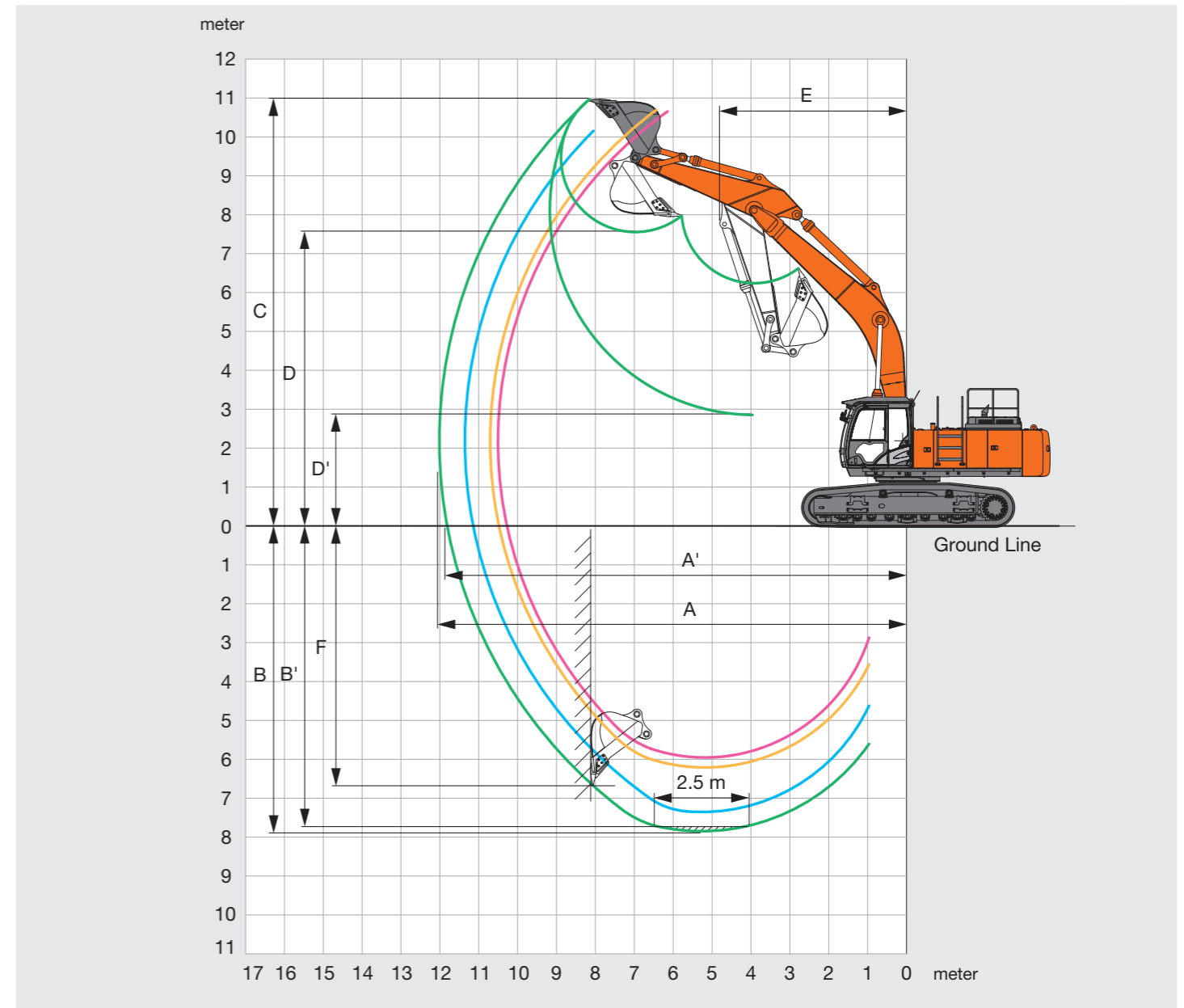

Unit: mm

Arm length	ZX470LC-5G			
	6.3 m BE-boom		7.0 m H-boom	
	2.5 m BE-arm	2.9 m BE-arm	2.9 m H-arm	3.4 m H-arm
A Max. digging reach	10 550	10 750	11 400	12 060
A' Max. digging reach (on ground)	10 320	10 520	11 220	11 860
B Max. digging depth	5 960	6 210	7 360	7 850
B' Max. digging depth (8° level)	5 780	6 050	7 160	7 710
C Max. cutting height	10 660	10 710	10 170	10 960
D Max. dumping height	7 160	7 360	6 910	7 570
D' Min. dumping height	3 510	3 170	3 330	2 860
E Min. swing radius	3 930	3 920	5 020	4 840
F Max. vertical wall	4 230	4 740	4 780	6 670

Excluding track shoe lug



# SPECIFICATIONS

## WORKING RANGES

### ZX470LCH-5G

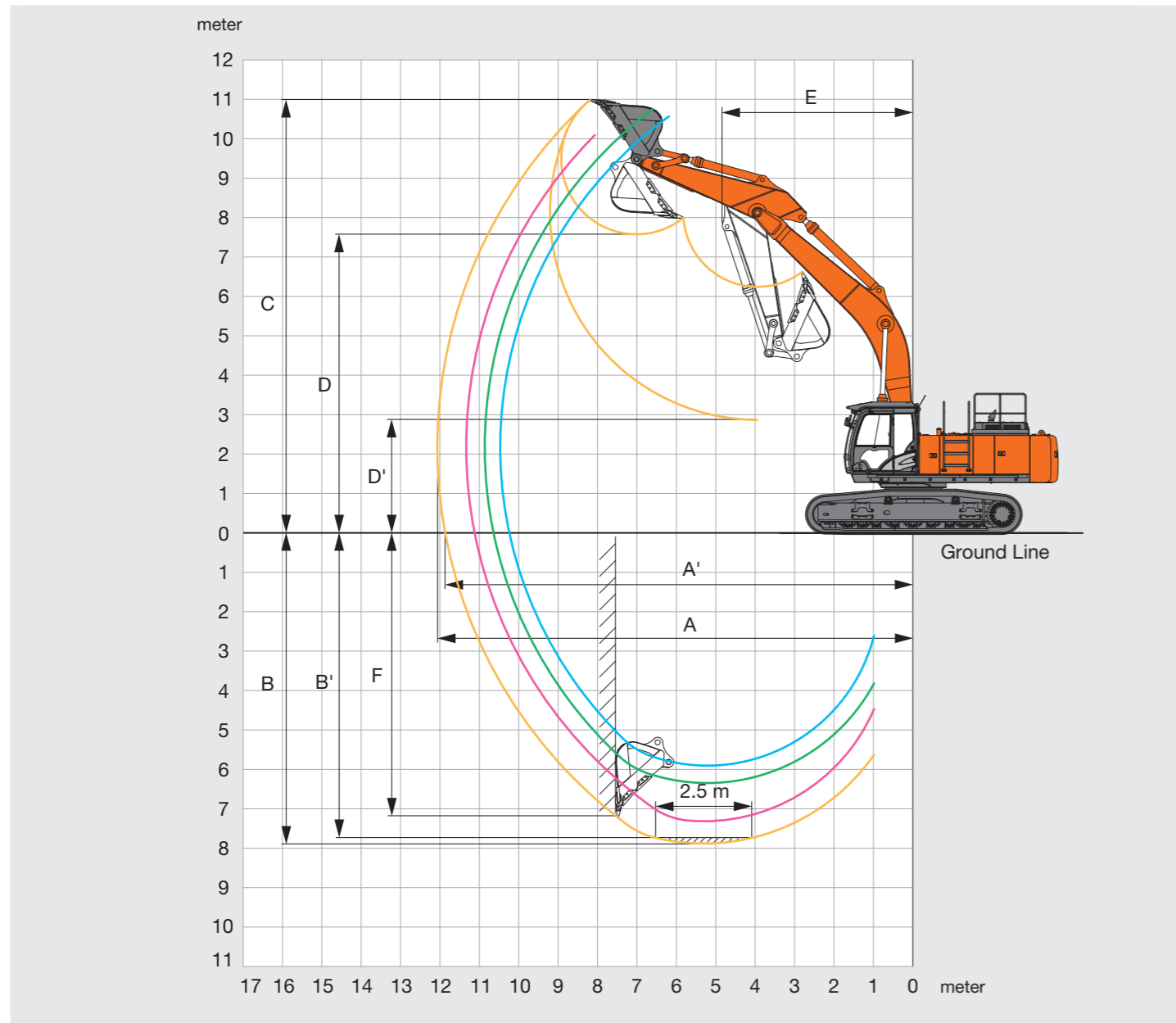

Arm length	ZX470LCH-5G			
	6.3 m BE-boom		7.0 m H-boom	
	2.5 m BE-arm	2.9 m BE-arm	2.9 m BE-arm	3.4 m H-arm
A Max. digging reach	10 460	10 750	11 330	12 060
A' Max. digging reach (on ground)	10 230	10 630	11 110	11 860
B Max. digging depth	5 880	6 220	7 290	7 860
B' Max. digging depth (B' level)	5 710	6 060	7 090	7 720
C Max. cutting height	10 570	10 700	10 080	10 980
D Max. dumping height	7 230	7 350	7 010	7 560
D' Min. dumping height	3 580	3 160	3 430	2 850
E Min. swing radius	4 090	3 930	5 020	4 840
F Max. vertical wall	4 350	4 740	4 360	7 190

Unit: mm

Excluding track shoe lug

## DIMENSIONS

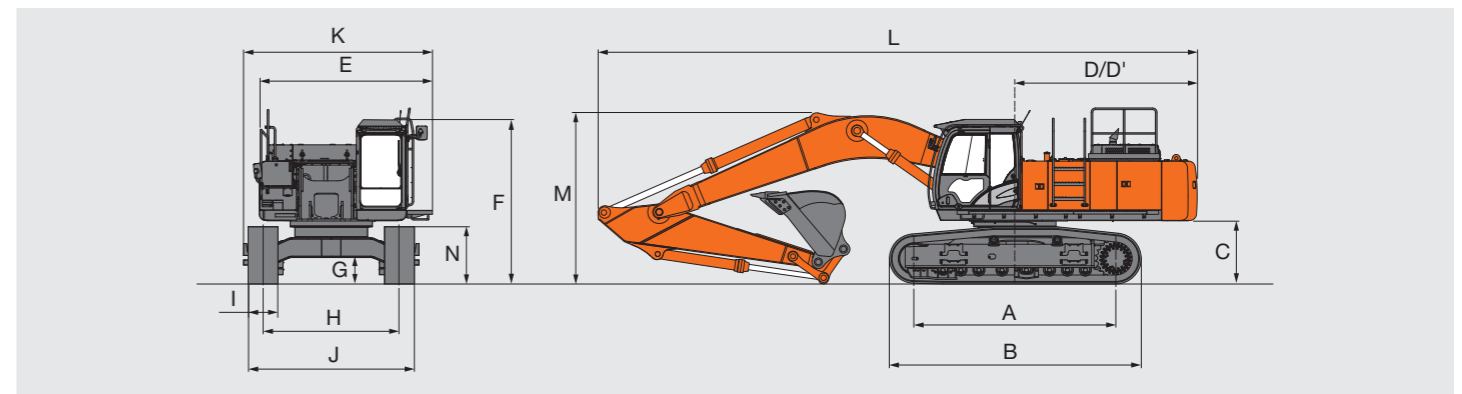

Unit: mm

Fixed gauge	ZX470LC-5G	ZX470LCH-5G
A Distance between tumbler	4 470	4 470
B Undercarriage length	5 470	5 470
*1 C Counterweight clearance	1 270	1 270
D Rear-end swing radius	3 670	3 670
D' Rear-end length	3 660	3 660
E Overall width upperstructure	3 480	3 480
F Overall height of cab	3 320	3 320
*1 G Min. ground clearance	535	535
H Track gauge	2 740	2 740
I Track shoe width	600 / 750	600
J Undercarriage width with 600 mm shoe	3 340	3 340
	with 750 mm shoe	—
K Overall width	3 820	3 820
L Overall length	12 050	12 040
M Overall height of boom	4 660	4 120
N Track height	1 150	1 150

\*1 Excluding track shoe lug

## BUCKET AND ARM DIGGING FORCES

### ZX470LC-5G

	ZX470LC-5G			
	6.3 m BE-boom		7.0 m H-boom	
	2.5 m BE-arm	2.9 m BE-arm	2.9 m BE-arm	3.4 m H-arm
Bucket digging force* ISO	285 kN ( 29 130 kgf)	285 kN ( 29 130 kgf)	285 kN ( 29 130 kgf)	286 kN ( 29 230 kgf)
Bucket digging force* SAE : PCSA	257 kN ( 26 240 kgf)	257 kN ( 26 240 kgf)	254 kN ( 25 940 kgf)	256 kN ( 26 140 kgf)
Arm crowd force* ISO	294 kN ( 30 050 kgf)	256 kN ( 26 140 kgf)	259 kN ( 26 450 kgf)	222 kN ( 22 640 kgf)
Arm crowd force* SAE : PCSA	285 kN ( 29 130 kgf)	249 kN ( 25 420 kgf)	252 kN ( 25 730 kgf)	215 kN ( 21 920 kgf)

### ZX470LCH-5G

	ZX470LCH-5G			
	6.3 m BE-boom		7.0 m H-boom	
	2.5 m BE-arm	2.9 m BE-arm	2.9 m BE-arm	3.4 m H-arm
Bucket digging force* ISO	295 kN (30 150 kgf)	295 kN (30 150 kgf)	295 kN (30 150 kgf)	296 kN (30 260 kgf)
Bucket digging force* SAE : PCSA	266 kN (27 070 kgf)	266 kN (27 070 kgf)	266 kN (27 070 kgf)	257 kN (26 240 kgf)
Arm crowd force* ISO	302 kN (30 770 kgf)	263 kN (26 860 kgf)	263 kN (26 860 kgf)	224 kN (22 850 kgf)
Arm crowd force* SAE : PCSA	294 kN (30 050 kgf)	256 kN (26 140 kgf)	256 kN (26 140 kgf)	215 kN (21 920 kgf)

\*At power boost

# LIFTING CAPACITIES (Without bucket)

Notes: 1. Ratings are based on ISO 10567.

- Lifting capacity does not exceed 75% of tipping load with the machine on firm, level ground or 87% full hydraulic capacity.
- The load point is the center-line of the bucket pivot mounting pin on the arm.
- \*Indicates load limited by hydraulic capacity.
- 0 m = Ground.

For lifting capacities, subtract bucket and quick hitch weight from lifting capacities without bucket.

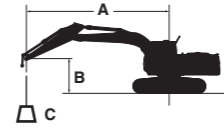

A: Load radius  
B: Load point height  
C: Lifting capacity

Notes: 1. Ratings are based on ISO 10567.

- Lifting capacity does not exceed 75% of tipping load with the machine on firm, level ground or 87% full hydraulic capacity.
- The load point is the center-line of the bucket pivot mounting pin on the arm.
- \*Indicates load limited by hydraulic capacity.
- 0 m = Ground.

For lifting capacities, subtract bucket and quick hitch weight from lifting capacities without bucket.

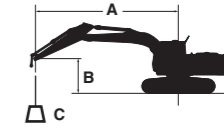

A: Load radius  
B: Load point height  
C: Lifting capacity

## ZX470LC-5G

Rating over-front Rating over-side or 360 degrees Unit : kg

Conditions	Load point height m	Load radius m										At max. reach		
		3.0		4.5		6.0		7.5		9.0		meter		
H-Boom 7.0 m H-Arm 3.4 m Counterweight 9 080 kg Shoe 600 mm	7.5							*11 560	10 300			*7 710	*7 710	8.64
	6.0							*12 150	10 050	*10 680	7 420	*7 570	6 850	9.41
	4.5			*20 430	*20 430	*15 620	13 510	*13 180	9 640	*11 770	7 240	*7 660	6 170	9.89
	3.0			*24 960	18 930	*17 810	12 630	*14 350	9 180	11 840	7 000	*7 970	5 800	10.1
	1.5			*15 420	*15 420	*19 460	11 920	15 250	8 770	11 580	6 770	*8 520	5 670	10.1
	0 (Ground)			*18 160	17 400	*20 170	11 500	14 910	8 480	11 390	6 600	*9 410	5 770	9.91
	-1.5	*13 070	*13 070	*25 000	17 380	*19 860	11 340	14 760	8 340	11 320	6 530	10 580	6 140	9.45
H-Boom 7.0 m BE-Arm 2.9 m Counterweight 9 080 kg Shoe 600 mm	6.0					*14 460	14 060	*12 780	9 890			*11 030	7 750	8.68
	4.5			*22 080	20 230	*16 440	13 240	*13 720	9 490	11 990	7 140	*11 410	6 880	9.20
	3.0					*18 470	12 380	*14 780	9 050	11 750	6 920	10 880	6 410	9.49
	1.5					*19 840	11 750	15 140	8 680	11 530	6 720	10 690	6 250	9.47
	0 (Ground)			*19 290	17 370	*20 180	11 420	14 870	8 430	11 380	6 590	10 980	6 370	9.23
	-1.5	*15 470	*15 470	*24 940	17 460	*19 510	11 350	14 770	8 350			11 860	6 840	8.73
	-3.0	*26 650	*26 650	*22 250	17 720	*17 750	11 470	*13 970	8 450			*12 920	7 890	7.92
BE-Boom 6.3 m BE-Arm 2.9 m Counterweight 9 080 kg Shoe 600 mm	7.5					*13 980	*13 980					*8 010	*8 010	7.13
	6.0					*14 790	14 350	*13 540	9 980			*7 760	*7 760	8.05
	4.5			*20 920	*20 920	*16 490	13 680	*14 230	9 690			*7 840	7 750	8.61
	3.0			*25 210	19 560	*18 480	12 900	*15 170	9 310			*8 200	7 200	8.88
	1.5			*27 650	18 390	*20 010	12 250	15 480	8 960			*8 900	7 030	8.89
	0 (Ground)			*27 690	17 960	*20 550	11 860	15 210	8 730			*10 090	7 210	8.64
	-1.5	*23 600	*23 600	*26 050	17 950	*19 860	11 740	15 140	8 670			*12 190	7 850	8.10
BE-Boom 6.3 m BE-Arm 2.5 m Counterweight 9 080 kg Shoe 600 mm	7.5					*14 650	14 460					*12 320	11 740	6.77
	6.0					*15 320	14 100	*14 020	9 780			*11 890	9 280	7.73
	4.5			*21 800	20 830	*16 930	13 410	*14 540	9 520			*12 000	8 060	8.31
	3.0					*18 780	12 640	*15 350	9 150			*12 550	7 450	8.59
	1.5					*20 100	12 020	15 330	8 820			12 460	7 270	8.60
	0 (Ground)			*27 160	17 750	*20 380	11 690	15 100	8 620			12 930	7 490	8.34
	-1.5			*25 130	17 820	*19 370	11 630	*14 960	8 610			*14 100	8 230	7.78

## ZX470LCH-5G

Rating over-front Rating over-side or 360 degrees Unit : kg

Conditions	Load point height m	Load radius m										At max. reach						
		3.0		4.5		6.0		7.5		9.0		meter						
H-Boom 7.0 m H-Arm 3.4 m Counterweight 9 080 kg Shoe 600 mm	7.5											*11 560	10 430			*7 710	*7 710	8.64
	6.0											*12 150	10 180	*10 680	7 520	*7 570	6 950	9.41
	4.5			*20 430	*20 430	*15 620	13 680	*13 180	9 770	*11 770	7 340	*7 660	6 260	9.89				
	3.0			*24 960	19 180	*17 810	12 800	*14 350	9 310	12 000	7 100	*7 970	5 890	10.1				
	1.5			*15 420	*15 420	*19 460	12 090	*15 340	8 900	11 740	6 870	*8 520	5 760	10.1				
	0 (Ground)			*18 160	17 650	*20 170	11 670	15 130	8 610	11 550	6 700	*9 410	5 860	9.91				
	-1.5	*13 070	*13 070	*25 000	17 640	*19 860	11 520	14 970	8 470	11 480	6 640	10 740	6 230	9.45				
H-Boom 7.0 m BE-Arm 2.9 m Counterweight 9 080 kg Shoe 600 mm	6.0					*14 460	14 240	*12 780	10 200			*11 030	7 860	8.68				
	4.5			*22 080	20 480	*16 440	13 410	*13 720	9 620	12 160	7 240	*11 410	6 980	9.20				
	3.0					*18 470	12 550	*14 780	9 180	11 920	7 030	11 040	6 510	9.46				
	1.5					*19 830	11 920	15 360	8 810	11 690	6 820	10 850	6 350	9.47				
	0 (Ground)			*19 290	17 620	*20 180	11 600	15 080	8 560	11 550	6 690	11 140	6 470	9.23				
	-1.5	*15 470	*15 470	*24 940	17 710	*19 510	11 520	14 980	8 480			12 030	6 950	8.73				
	-3.0	*26 650	*26 650	*22 250	17 980	*17 750	11 640	*13 970	8 580			*12 920	8 010	7.92				
BE-Boom 6.3 m BE-Arm 2.5 m Counterweight 9 080 kg Shoe 600 mm	7.5					*14 650	14 630					*12 320	11 880	6.78				
	6.0					*15 320	14 280	*14 020	9 910			*11 890	9 400	7.73				
	4.5			*21 800	21 080	*16 940	13 590	*14 540	9 650			*12 000	8 170	8.31				
	3.0					*18 780	12 810	*15 350	9 280			*12 550	7 560	8.59				
	1.5					*20 100	12 190	15 540	8 950			12 640	7 380	8.60				
	0 (Ground)			*27 160	18 000	*20 380	11 860	15 310	8 750			13 110	7 600	8.34				
	-1.5			*25 130	18 070	*19 370	11 800	*14 960	8 740			*14 110	8 350	7.78				

## BASIC MACHINE (WITHOUT COUNTERWEIGHT)

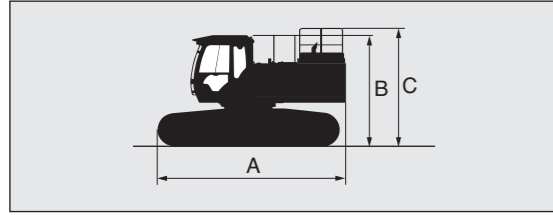

Fixed gauge	Shoe type	Shoe width	Overall width	Weight	A	B	C
ZX470LC-5G	Triple grouser	600 mm	3 340 mm	28 200 kg	5 690 mm	3 240 mm	3 580 mm
	Triple grouser	750 mm	3 490 mm	29 000 kg			
ZX470LCH-5G	Triple grouser	600 mm	3 340 mm	28 700 kg	5 690 mm	3 360 mm	3 580 mm

## BASIC MACHINE FITTED WITH BOOM AND NO SIDEWALK

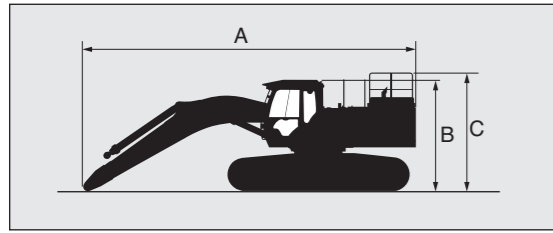

Fixed gauge	Boom length	Shoe type	Shoe width	Overall width	Weight	A	B	C
ZX470LC-5G	6.3 m BE	Triple grouser	600 mm	3 340 mm	33 600 kg	9 160 mm	3 240 mm	3 580 mm
		Triple grouser	750 mm	3 490 mm	34 400 kg			
	7.0 m H	Triple grouser	600 mm	3 340 mm	33 600 kg	9 940 mm		
		Triple grouser	750 mm	3 490 mm	34 400 kg			
ZX470LCH-5G	6.3 m BE	Triple grouser	600 mm	3 340 mm	34 100 kg	9 160 mm	3 360 mm	3 580 mm
	7.0 H m	Triple grouser	600 mm	3 340 mm	34 000 kg	9 940 mm		

## BASIC MACHINE WITH FRONT AND SIDEWALK

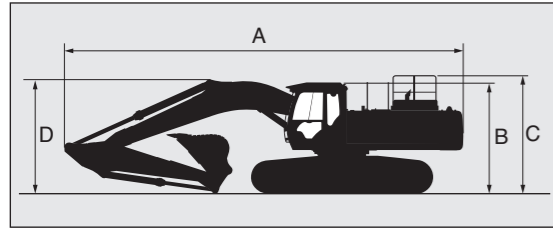

Fixed gauge	Boom length	6.3 m BE		7.0 m H	
		Arm length	2.5 m BE	2.9 m BE	2.9 m BE
ZX470LC-5G	A	11 490 mm	11 290 mm	12 050 mm	12 070 mm
	B	3 240 mm			
	C	3 580 mm			
	D	4 200 mm	4 120 mm	3 900 mm	3 720 mm
ZX470LCH-5G	A	11 490 mm	11 360 mm	12 100 mm	12 030 mm
	B	3 360 mm			
	C	3 580 mm			
	D	4 130 mm	3 880 mm	3 740 mm	3 450 mm

## ARM AND BUCKET

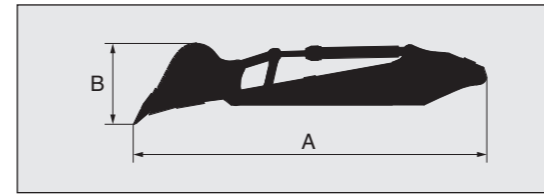

### ZX470LC-5G

Arm	Bucket Capacity ISO heaped	A	B	Overall width	Weight
2.5 m BE	2.50 m <sup>3</sup>	5 760 mm	1 400 mm	1 770 mm	4 620 kg
2.9 m BE	2.30 m <sup>3</sup>	6 030 mm	1 340 mm	1 660 mm	4 350 kg
3.4 m H	1.90 m <sup>3</sup>	6 430 mm	1 270 mm	1 540 mm	4 240 kg
	2.10 m <sup>3</sup>	6 430 mm	1 270 mm	1 630 mm	4 300 kg

### ZX470LCH-5G

Arm	Bucket Capacity ISO heaped	A	B	Overall width	Weight
2.5 m BE	2.50 m <sup>3</sup>	5 650 mm	1 470 mm	1 820 mm	5 010 kg
2.9 m BE	2.30 m <sup>3</sup>	5 950 mm	1 460 mm	1 700 mm	4 800 kg
3.4 m H	1.90 m <sup>3</sup>	6 440 mm	1 300 mm	1 500 mm	4 720 kg

## BUCKET

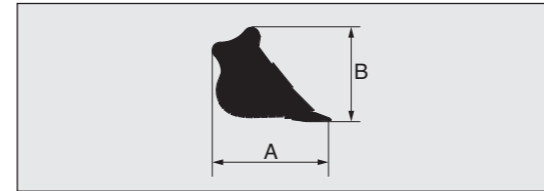

### ZX470LC-5G (Hoe bucket)

Bucket Capacity ISO heaped	A	B	Overall width	Weight
1.15 m <sup>3</sup>	1 800 mm	1 350 mm	1 210 mm	1 070 kg
1.40 m <sup>3</sup>	1 800 mm	1 350 mm	1 410 mm	1 170 kg
1.60 m <sup>3</sup>	1 960 mm	1 570 mm	1 360 mm	1 480 kg
1.90 m <sup>3</sup>	1 960 mm	1 570 mm	1 540 mm	1 590 kg
2.10 m <sup>3</sup>	1 960 mm	1 570 mm	1 630 mm	1 650 kg
2.30 m <sup>3</sup>	1 950 mm	1 660 mm	1 660 mm	1 800 kg
2.50 m <sup>3</sup>	1 950 mm	1 660 mm	1 770 mm	1 870 kg
2.65 m <sup>3</sup>	1 950 mm	1 660 mm	1 860 mm	1 930 kg

### ZX470LCH-5G (Rock bucket)

Bucket capacity ISO heaped	A	B	Overall width	Weight
1.90 m <sup>3</sup>	2 030 mm	1 480 mm	1 500 mm	2 070 kg
2.10 m <sup>3</sup>	1 950 mm	1 650 mm	1 580 mm	2 170 kg
2.30 m <sup>3</sup>	1 950 mm	1 650 mm	1 700 mm	2 260 kg
2.50 m <sup>3</sup>	1 950 mm	1 650 mm	1 820 mm	2 360 kg

### COUNTERWEIGHT 9 080 kg

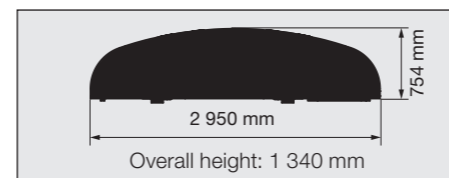

### LEFT FRONT SIDEWALK 44 kg

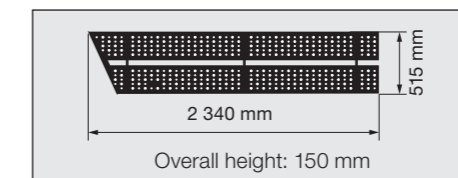

### LEFT REAR SIDEWALK 30 kg

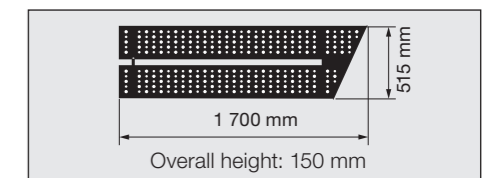

Standard and optional equipment may vary by country, so please consult your Hitachi dealer for details.

● : Standard equipment ○ : Optional equipment — : Not applicable

	ZX470LC-5G	ZX470LCH-5G
<b>ENGINE</b>		
Auto idle system	●	●
Cartridge-type engine oil filter	●	●
Cartridge-type fuel filter	●	●
Dry-type air double filter with evacuator valve (with air filter restriction switch for monitor)	●	●
Fan guard	●	●
Fuel pre-filter	●	●
Power mood control [H/P (High Power) PWR(Power) ECO(Economy) ]	●	●
Isolation-mounted engine	●	●
Pre-cleaner	○	○
Radiator, oil cooler with dust protective net	●	●
Radiator reserve tank	●	●
50 A alternator	●	●

<b>HYDRAULIC SYSTEM</b>		
Accessories for breaker	—	○
Accessories for breaker & crusher	—	○
Accessories for 2 speed selector	—	○
Auto power lift	●	●
Boom mode selector system	●	●
Control valve with main relief valve	●	●
Drain filter	●	●
Engine speed sensing system	●	●
E-P control system	●	●
Extra port for control valve	●	●
Full-flow filter	●	●
Pilot filter	●	●
Power boost	●	●
Quick warm-up system for pilot circuit	●	●
Shockless valve in pilot circuit	●	●
Suction filter	●	●
Work mode selector	●	●

<b>CAB</b>		
Additional fuse box	●	●
Adjustable armrests	●	●
All-weather sound suppressed steel cab	●	●
AM-FM radio	●	●
Ashtray	●	●
Auto control air conditioner	●	●
Auto-idle selector	●	●
AUX. terminal and storage	○	○

	ZX470LC-5G	ZX470LCH-5G
H/R cab	●	●
OPG top guard fitted Level II (ISO10262)	●	●
OPG front guard fitted Level II (ISO10262)	○	○
Laminated straight glass front window	●	●
Left side window can be opened	●	●
Cigarette lighter	●	●
Drink holder	●	●
Engine shut-off cable	●	●
Electric double horn	●	●
Evacuation hammer	●	●
Fire extinguisher bracket	○	○
Floor mat	●	●
Footrest	●	●
Front window washer	●	●
Glove compartment	●	●
Hot & cool box	●	●
Intermittent windshield wiper	●	●
Key cylinder light	●	●
LED room light with door courtesy	●	●
Pilot control shut-off lever	●	●
Rear tray	●	●
Retractable seat belt	●	●
Rubber radio antenna	●	●
Seat : Adjustable reclining mechanical suspension	●	●
Short wrist control levers	●	●
Storage box	●	●
Sun visor (front)	○	○
Sun visor (side)	○	○
Transparent roof with slide curtain	●	●
2 speaker	●	●
6 fluid-filled elastic mounts	●	●
12 V power outlet	○	○
24 V cigarette lighter	●	●

<b>MONITOR SYSTEM</b>		
Alarm buzzers: overheat, engine oil pressure	●	●
Alarms: overheat, engine warning, engine oil pressure, alternator, minimum fuel level, air filter restriction, work mode, etc	●	●
Display of meters: water temperature, hour, fuel rate, clock	●	●
Other displays: work mode, auto-idle, glow, operating conditions etc	●	●

Standard and optional equipment may vary by country, so please consult your Hitachi dealer for details.

● : Standard equipment ○ : Optional equipment — : Not applicable

	ZX470LC-5G	ZX470LCH-5G
<b>LIGHTS</b>		
2 working lights	●	●
2 cab lights	●	●
4 cab lights	○	○
Additional working lights (boom right side)	○	○

<b>UPPER STRUCTURE</b>		
Electric fuel refilling pump with auto stop	○	○
Auto-grease lubricator	○	○
Electrical grease pump with hose-reel	○	○
Fuel level float	●	●
Hydraulic oil level gauge	●	●
Ladder	●	●
Rear view camera	○	○
Rear view mirror (right & left side)	●	●
Side walk (cab side)	●	●
Swing parking brake	●	●
Tool box	●	●
Utility space	●	●
170 Ah batteries	●	●
2.3 mm thickness undercover	●	—
4.5 mm thickness undercover	—	●
9 080 kg counterweight	●	●

<b>UNDERCARRIAGE</b>		
Bolt-on sprocket	●	●
Full track guard	—	●
Hydraulic track adjuster	●	●
Idler track guard	●	—
Reinforced track links with pin seals	●	●
Travel motor covers	●	●
Travel parking brake	●	●
Track undercover	○	○
Upper and lower rollers	●	●
1 track guard (each side)	—	—
2 track guard (each side)	●	—
600 mm triple grouser shoes	●	●
750 mm shoe with standard track guard	○	—

	ZX470LC-5G	ZX470LCH-5G
<b>FRONT ATTACHMENTS</b>		
Attachment basic piping	○	○
Centralized lubrication system	●	●
Damage prevention plate and square bars	●	●
Dirt seal on all bucket pins	●	●
Flanged pin	●	●
Monolithically cast bucket link A	●	●
1.9 m <sup>3</sup> (ISO heaped) bucket	○	—
2.1 m <sup>3</sup> (ISO heaped) bucket	●	—
1.9 m <sup>3</sup> (ISO heaped) rock bucket (with dual type side shrouds)	—	●
7.0 m H-boom and 3.4 m H-arm	●	●
6.3 m BE-boom	○	○
2.5 m BE-arm	○	○
2.9 m BE-arm	○	○
Reinforced weld link A	—	●
Reinforced link B	—	●

<b>MISCELLANEOUS</b>		
Anti-slip steps and handrails	●	●
Lockable fuel refilling cap	●	●
Lockable machine covers	●	●
Onboard information controller	●	●
Standard tool kit	●	●
Theft deterrent system	●	●
Travel direction mark on track frame	●	●

<b>OTHERS</b>		
Global e-service	●	●

# Made By Hitachi

A global standard of quality

When you purchase a Hitachi Construction Machinery Group product, you are the owner of a superior quality machine characterized by sophisticated Japanese engineering and proficient manufacturing. By applying the same strict manufacturing regiment at our production bases around the globe, we are able to maintain global quality standards without compromise. Through these efforts we promise you reliable solutions you can count on.

Built on the foundation of superb technological capabilities, Hitachi Construction Machinery is committed to providing leading solutions and services as a reliable partner to the business of our customers worldwide.

## ZAXIS-5G Concept

At the ready to give you performance and reliability that empowers your work. ZAXIS-5G series excavators comes with a load of improvements to withstand tough working environments in the form of strengthened front attachments, reinforced undercarriage and a comfortable, luxury cab. On top of that, ZAXIS-5G machines boast impressive fuel economy, swift front movements, and easy maintenance - all of which give your workday a productivity-boosting advantage.

Follow us on:



Facebook



Youtube

 **Hitachi Construction Machinery**  
**Asia and Pacific Pte. Ltd.**  
[www.hitachicm.com.sg](http://www.hitachicm.com.sg)

These specifications are subject to change without notice.

Illustrations and photos show the standard models, and may or may not include optional equipment, accessories, and all standard equipment with some differences in color and features.

Before use, read and understand the Operator's Manual for proper operation.