

LX190/230

HITACHI

# LX190 LX230

W H E E L L O A D E R

**LX190/LX230**

**Engine Rated Power :**

165 kW (225 PS) / 198 kW (270 PS)

**Operating Weight :**

19 770 kg / 21 770 kg

**Bucket Capacity :**

2.8 m<sup>3</sup>—3.5 m<sup>3</sup> / 3.1 m<sup>3</sup>—4.0 m<sup>3</sup>



The choice for increasing productivity

# Ideal Match

Engine power	LX190 165 kW (225 PS)	LX230 198 kW (270 PS)
Bucket capacity	3.5 m <sup>3</sup>	4.0 m <sup>3</sup>
Breakout force	166 kN (16 900 kgf)	198 kN (20 200 kgf)

Hitachi has created the ideal performance match to increase productivity. It is called the BMC Matching Control Concept.



**Powerful, clean-operating engine**  
Clean-operating and powerful engine complies with Emission Regulation U.S. EPA Tier 2.

**Finger-tip operated shift lever**  
The operator can drive with ease needing only a light-touch to change travel direction or gear range.



**Restriction valve**  
Reduces the shock incurred when stopping the arm, helping to provide smooth operation.

**Axle with torque proportioning differential**  
Helps to reduce wheel spinning when operating on tough terrain.



**Downshift switch (DSS) ①**  
**Upshift switch (USS) ②**  
Allows the operator to change gears without using the shift lever. Each press of the downshift switch or upshift switch changes the gear up or down while the operator keeps his hand on the loader control lever.





**Clear view from cab front**  
A pillar-less design gives an unobstructed view of the front.



**Easy-to-monitor instrument panel**



**Deluxe suspension seat**  
The comfortable cloth-covered seat offers both suspension and reclining adjustment.



**ROPS/FOPS\* cab**  
This rigid cab is ready "just in case" to help protect the operator from falling objects or during a rollover. The rear-hinged door makes entry and exit easy.

\*ROPS: Rollover Protective Structure. Conforms to ISO3471, 1994

\*FOPS: Falling-Object Protective Structure. Conforms to ISO3449, 1992 Level II



**Electronically operated parking brake**  
A simple press of a button sets and releases the parking brake.

**Independent front and rear service brakes**  
Separate brake lines for the front and rear wheels means that one will be available for braking in the unlikely event that the other fails.



**Front control lever lock**  
Locks the controls to prevent unintentional operation when getting in and out of the cab.



**Fully enclosed engine fan guard**  
A guard completely encloses the engine fan.



**Shift lever lock**  
Can be easily set to prevent accidental operation of the shift lever.

**Front arm can be lowered with engine stopped**  
An accumulator in the hydraulic system for the front arm allows it to be lowered even if the engine has been stopped.

# deal Match for Comfort & Safety

For boosting productivity and operator protection.



**Switches are easy to view and reach**

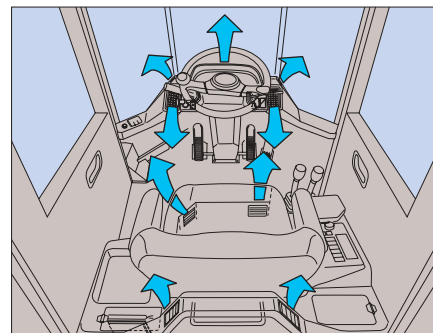

**External air induction air conditioning (Automobile type)**  
This powerful air conditioning can be switched between re-circulating air inside the cab or drawing it in from outside.

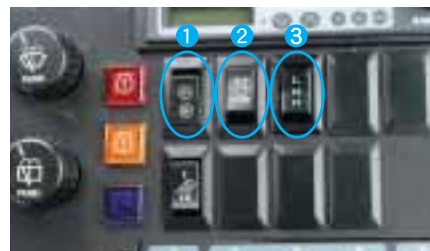

**1 Clutch cut-off switch**  
Left brake pedal can be switched between work mode for loader operations and travel mode for traveling.



**Front 1 and rear 2 defrosters reduce fogging for clear visibility**

**AM/FM stereo radio with automatic station selection**  
The operator can easily select the desired station using the touch-type LCD panel.

**3 3-mode switch**  
Automatic transmission provides selection among three power modes: (L) gives priority to traveling; (M) is an intermediate range; (H) is for loading operations.



**Sun visor reduces glare**





- 1 Fuel cap
- 2 Hydraulic fluid cap
- 3 Transmission fluid cap
- 4 Battery box
- 5 Side cover
- 6 Cab door

### Centralized greasing system

This system makes it easy to grease hard-to-reach areas, such as the bottom pin of the bucket cylinder, helping to promote crucial regular maintenance.

### Easy-to-check fluid level gauge

This gauge allows the level of the hydraulic and transmission fluids to be checked from ground level with just a glance.

### Restricted access

Locks have been added to crucial areas to help ward off unauthorized access or vandalism. The fuel cap and side covers can be locked with the engine key. The following areas can be locked.

### Large side cover with damper

The large side cover opens to provide easy access. In addition, items requiring daily maintenance have been centrally located on the left side for faster servicing.



# Easy Maintenance

Prime condition with minimum effort.



### Wide steps

These large steps make entry and exit easy.

### Wide-opening battery cover

Swings out of the way for fast battery maintenance or replacement.

LX230-7

Note: This photo shows the model with the inspection covers open. Always close these inspection covers before operation.

## Wide Range of Attachments

### Buckets



#### Standard general purpose bucket with bolt on cutting edges

Best for stock piling loose dirt and rock.

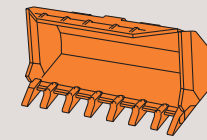

#### General purpose bucket with bolt on teeth

A good choice for relatively dense material, such as dense dirt, gravel or dirt with clumps and rocks.

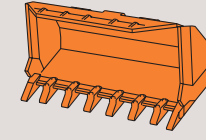

#### Rock bucket with bolt on teeth

This is the bucket for scooping up blasted rock or gravel.

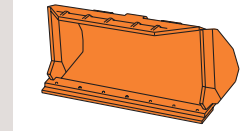

#### Rock bucket with bolt on teeth & segments

Used for handling blasted rock, sand, dirt and other quarried materials.

Note: Refer to Specification Catalog for details.

### Tires

#### Tread patterns



- L3:** Standard groove depth.
- L4:** Grooves are 1.5 times deeper than L3.
- L5:** Grooves are 2.5 times deeper than L3.

#### Rock tire designs and applications

- **Nylon breaker**  
Perfect for hard surfaces and standard road applications.
- **Steel breaker**  
This is the tire for use where the stones have sharp edges.
- **Side steel breaker**  
The choice for harsh conditions where stones have sharp edges.

### Attachments & Options



#### Lumber forks\* (LX190)

Helps handle square beams, lumber or other such material. Fork width can be manually adjusted to the width of the load.



#### Log grapple

This dedicated attachment allows the loader to handle logs and other round materials.



#### Lumber grapple

Forks pick up the square material and the upper arm comes down to hold the load in place during transport.

#### High-lift arm

This extended arm gives higher dumping clearance.



#### Quick coupler (Hydraulic type)\* (LX190) (For quick attachment changing)

Allows attachments to be mounted or removed by controls in the cab.

\*: Special option on LX230.

## DIMENSIONS

Unit : mm

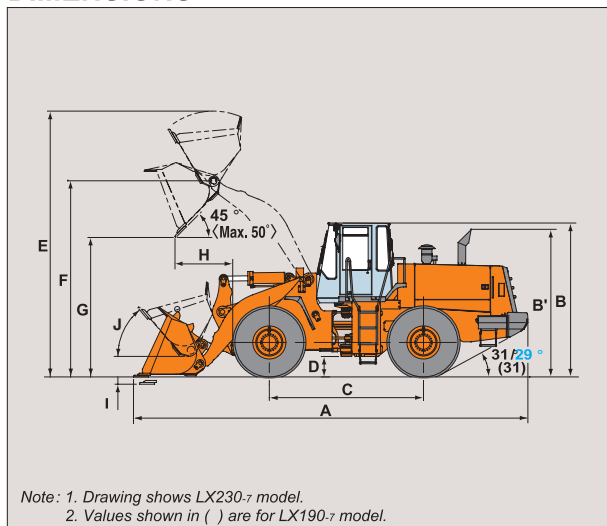

	LX190-7	LX230-7	
		26.5 tires	23.5 tires
A Overall length	8 510	8 650	8 700
B Height to top of cab	3 410	3 470	3 410
B' Height to top of exhaust	3 250	3 310	3 250
Width over tires	2 930	2 980	2 930
C Wheelbase	3 400	3 400	
D Ground clearance	460	520	460
Tread width	2 300	2 300	
Bucket width	3 050	3 150	
Turning radius (centerline of outside tire)	5 820	5 820	
Loader clearance circle, bucket in carry position	6 800	6 890	
E Overall operating height	5 640	5925	5865
F Height to hinge pin, fully raised	4 180	4 385	4 325
G Dumping clearance 45 degree, full height	2 985	3 135	3 075
H Reach, 45 degree dump, full height	1 135	1 210	1 275
Reach, 45 degree dump, 7ft (2.13m) clearance	1 765	1 900	1 935
I Digging depth (horizontal digging angle)	100	100	160
J Max. roll back at carry position	50 deg.	50 deg.	50 deg.

Note: General purpose bucket with bolt on cutting edges. Numerals in blue indicate size with optional tires.

## SPECIFICATIONS

		LX190-7	LX230-7	
			26.5 tires	23.5 tires
Bucket capacity (ISO heaped) with bolt on cutting edges	m <sup>3</sup>	3.5	4.0	
Operating weight	kg	19 770	21 770	21 310
Hydraulic cycle times	Lift arm Raise/Lower	6.2 / 3.3		6.4 / 3.6
	Bucket dump	1.4		1.5
Max. travel speed	Forward/Reverse	34.5 / 37.0	34.5 / 36.5	32.5 / 35.0
Transmission		4-speeds (F/R) full powershift transmission	4-speeds (F/R) full powershift transmission	
Breakout force	kN (kgf)	166 (16 900)	198 (20 200)	
Engine	Type	Mitsubishi 6D24TL		Mitsubishi 6D24TL
	Rated power (DIN 6271,net)	165 / 2 100 (225 / 2 100)		198 / 2 100 (270 / 2 100)
	Rated power (SAE J1349,net)	165 / 2 100 (222 / 2 100)		198 / 2 100 (266 / 2 100)
	Piston displacement	L		11.945
Service brake		Wet disc type		Wet disc type
Parking brake		Wet disc type		Wet disc type
Tire size		23.5-25-16PR (L3)	26.5-25-16PR (L3)	23.5-25-20PR (L3)
Fuel tank capacity	L	320	370	

Note: Specifications are based on machine with all standard equipment.

### Standard Equipment

#### Cab

- ROPS/FOPS cab
- Seat with mechanical suspension and deluxe cloth covering (with seat belt)
- Tilt steering column ● Intermittent front windshield wiper (with washer)
- Rear windshield wiper (with washer) ● Sun visor ● AM/FM stereo radio
- Cab interior light linked to door ● Front control lever lock
- Transmission shift lever lock ● Hot-and-cool box: LX230-7 ● Safety glass
- Lunch box tray ● Cup holder ● Rear defroster ● Front-side defroster

#### Features

- Electronically controlled automatic transmission
- Front/rear torque proportioning differential
- Downshift switch (DSS) ● Upshift switch (USS)
- Auto transmission 3 mode selection switch ● Clutch cut-off switch
- Arm height kickout ● Automatic bucket return-to-dig control
- Two-function hydraulic valve with two levers

#### Others

- 3.5m<sup>3</sup> general purpose bucket with bolt on cutting edges: LX190-7
- 4.0m<sup>3</sup> general purpose bucket with bolt on cutting edges: LX230-7
- Parking break with electric switch ● Pre-air cleaner: LX230-7
- Reverse warning alarm ● 23.5-25-16PR (L3) tires: LX190-7
- 26.5-25-20PR (L3) tires: LX230-7

Note: Standard equipment may vary depending on countries, so please consult your Hitachi dealer for details.

### Optional Equipment

#### LX190-7

- 3.3m<sup>3</sup> general purpose bucket with bolt on teeth
- 3.5m<sup>3</sup> general purpose bucket with bolt on teeth & segments
- 2.9m<sup>3</sup> rock bucket with bolt on teeth
- 3.0m<sup>3</sup> rock bucket with bolt on teeth & segments
- Lumber forks ● Log grapple ● Lumber grapple ● High-lift arm
- Quick coupler: Hyd. type ● Air conditioning ● Ride control system

#### LX230-7

- 3.8m<sup>3</sup> general purpose bucket with bolt on teeth
- 4.0m<sup>3</sup> general purpose bucket with bolt on teeth & segments
- 3.3m<sup>3</sup> rock bucket with bolt on teeth
- 3.4m<sup>3</sup> rock bucket with bolt on teeth & segments
- Lumber forks (Special option) ● Log grapple ● Lumber grapple
- High-lift arm ● Quick coupler: Hyd. type ● Air conditioning
- Ride control system

Note: Optional equipment may vary depending on countries, so please consult your Hitachi dealer for details.

These specifications are subject to change without notice. Illustrations and photos show the standard models, and may or may not include optional equipment, accessories, and all standard equipment with some differences in color and features. Before use, go through Operator's Manual for proper operation.

## Hitachi Construction Machinery Co., Ltd.

Head Office: 5-1 Koraku 2-chome, Bunkyo-ku,  
Tokyo 112-8563, Japan

Telephone: (03)3830-8050

Facsimile: (03)3830-8204

KL-E116P

03.12 (CD/KA, GT<sub>3</sub>)