

LX30

HITACHI

LX30

W H E E L L O A D E R

- **Engine Rated Power** : 27.2 kW (37 PS)
- **Operating Weight** : Canopy / Cab
3 265 kg (7 200 lb) / 3 440 kg (7 590 lb)
- **Backhoe Bucket** : ISO Heaped
0.5 m³ (0.7 yd³) – 0.8 m³ (1.0 yd³)

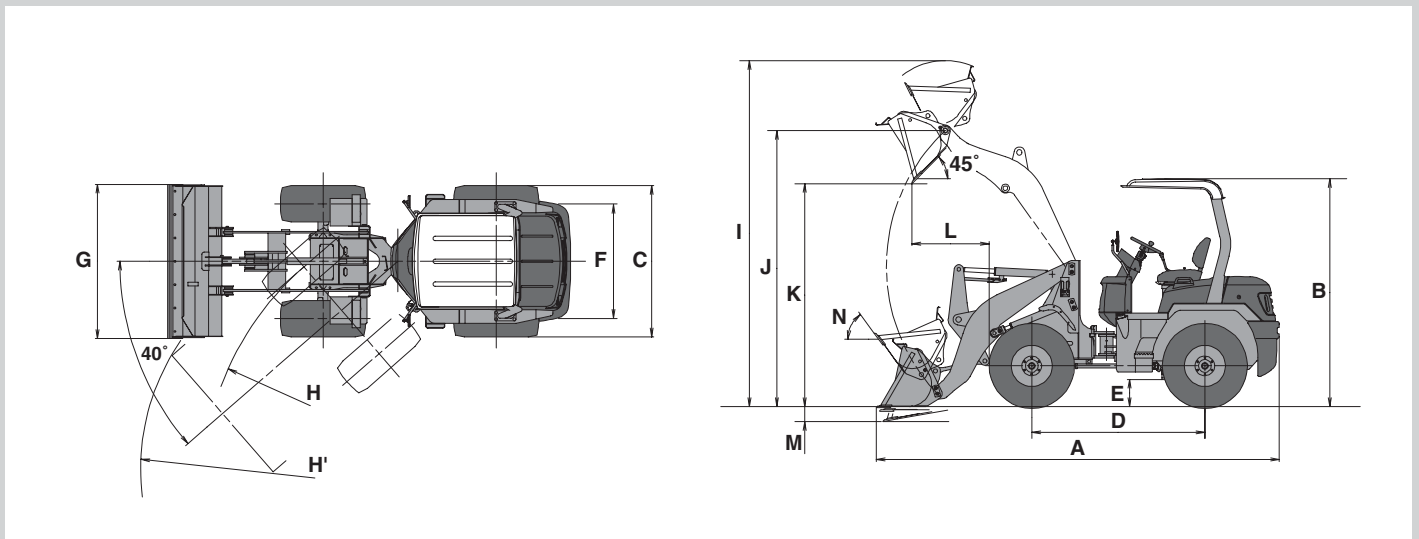

Unit : mm (ft in)

	LX30-7
A Overall length	4 425 (14'6")
B Height to top of canopy and cab	2 495 (8'2") / 2 540 (8'4")
C Width over tires	1 655 (5'5")
D Wheel base	1 900 (6'3")
E Ground clearance	295 (6'0")
F Tread	1 260 (4'2")
G Bucket width	1 690 (5'7")
H Turning radius (centerline of outside tire)	3 220 (10'7")
H' Loader clearance circle, bucket in carry position	3 845 (12'7")
I Overall operating height	3 795 (12'5")
J Height to hinge pin, fully raised	3 030 (9'11")
K Dump clearance 45 degree, full height	2 455 (8'1")
L Reach, 45 degree dump, full height	845 (2'9")
Reach, 45 degree dump, 7 ft (2.13 m) clearance	1 120 (3'8")
M Digging depth (horizontal digging angle)	50 (2")
N Max. roll back at carry position	54 deg.
Tire size	15.5 / 60 - 18 - 8PR (L2)

Note: General purpose bucket with bolt on cutting edges.

STANDARD & OPTIONAL EQUIPMENT

	LX30		LX30		LX30
ENGINE		Indicator lights: Turn signals / Warning flashers / Park brake / High gear	●	Light material handling bucket with bolt on cutting edges : 0.7 m ³ (0.9 yd ³ : ISO heaped)	□
Coolant recovery tank	●	Parking brake (negative)	●	Wide (daily & livestock) bucket with bolt on cutting edges : 0.8 m ³ (1.0 yd ³ : ISO heaped)	□
Environmentally friendly engine oil drain	●	12-volt AM radio (for cab model only)	□	Quick-coupler and mechanical control system for quick-coupler locking pins, lines, and valves	□
Quick-release fuel filter and water separator	●	12-volt AM/FM radio (for cab model only)	□	Full line of Hitachi buckets for quick coupler with selection of bolt-on cutting edges	
Glow system (for cold start)	●	Ride control system (APS: Anti-pitching System)*	□	General purpose bucket with bolt on cutting edges : 0.5 m ³ (0.7 yd ³ : ISO heaped)	□
Double-element air cleaner	□			Light material handling bucket with bolt on cutting edges : 0.6 m ³ (0.8 yd ³ : ISO heaped)	□
Clog prevention net and fan	□			Light material handling bucket with bolt on cutting edges : 0.7 m ³ (0.9 yd ³ : ISO heaped)	□
		OPERATOR'S STATION		Wide (daily & livestock) bucket with bolt on cutting edges : 0.8 m ³ (1.0 yd ³ : ISO heaped)	□
POWER TRAIN		Canopy		Full line of construction utilityforks, pallet forks, and attachments*	
Hydrostatic (HST) transmission, electronic shift control, twist-grip lever, hydrostatic oil cooler, inching pedal, and two speeds forward and reverse	●	FRP roof	●	Lumber and manure fork : Max load 850 kg (1 870 lb) (pin on type)	□
		ROPS** / FOPS***	□	Lumber and manure fork : Max load 800 kg (1 760 lb) (for quick coupler)	□
		With front curved glass, 2 pillars and wiper	□	Roll grab : Max load 700 kg (1 540 lb) (pin on type)	□
		Cab		Roll grab : Max load 600 kg (1 320 lb) (for quick coupler)	□
		Steel Cab (without ROPS / FOPS) /	□		
HYDRAULIC SYSTEM		Front windshield washers / Safety grass grass		TIRES	
Automatic bucket return-to-dig control	●	ROPS** / FOPS*** / Multi-plane isolation	□	- Bias ply :	
Hydraulic filters, vertical mounting	●	mounted for noise/vibration reduction / Front and rear windshield washers / Safety grass	□	15.5/60-18-8PR (L2)	●
Two-function hydraulic valve with joystick control (mechanical controlled)	●	Vinyl cab with front glass and vinyl shielding	□	Tire chain (H type)	□
Three-function hydraulic valve with joystick control and auxiliary lever for third function (mechanical controlled)	□	Heater / Defroster (Cab model only)	□	Spare tire with rim	□
		Air conditioning (for cab, factory or dealer installed)	□	Spare rim	□
ELECTRICAL		Seat belt, 50mm (2 in.)	●	Solid tires with rims per machine	□
12-volt electrical system	●	Seat belt, 76 mm (3 in.), with retractor*	□	Spare solid tire with rim	□
Standard batteries (1), 12 volt with 490 CCA, 123-min. rated reserve	●	Seat, vinyl covered, adjustable for fore-aft position	□	Standard tires and galvanized rims per machine	□
Alternator, 40 amps and 12 volts	●	Seat, vinyl covered, mechanical suspension, adjustable for weight-height, fore-aft position, backrest tilt	□	1 spare standard tire and galvanized rim	□
Alternator, high capacity, 60 amps and 12 volts	●	Seat, vinyl covered, adjustable for fore-aft position, backrest tilt	□	1 spare galvanized rim	□
Lights	●	Rubber floor mat			
Driving with guards / Turn signals and flashers / Stop, tail and buck-up lights / Conform to SAE 99	●	Steering wheel, textured with spinner knob		OTHERS	
Work lights on cab, front (2) (Cab model only)	□	Rear view mirrors, outside (2)		Vandal protection, includes lockable engine enclosure, and fuel fill	●
Work lights, rear (1) or (2) (Cab model only)	□	Handholds, steps, and slip resistant		Counter weight, built-in	●
Horn, with push button in center of steering wheel	●			Power steering	●
Conforms to SAE J994, J1446		LOADER LINKAGE		Lifting lig (4-point support)	□
Buckup alarm	●	Z-bar loader linkage provides "high bucket breakout"	●		
Monitor and alarm system, multi-function electronic	●	High-lift boom*	□		
Audible and visual warning include					
Analog instruments: Engine coolant temperature / Fuel level / Hour-meter	●	BUCKETS AND ATTACHMENTS			
Operator warning lights: Brake oil / Engine oil pressure / Alternator voltage (charge)	●	Full line of Hitachi pin on buckets with selection of bolt-on cutting edges, and bolt-on teeth*			
		General purpose bucket with bolt on cutting edges : 0.5 m ³ (0.7 yd ³ : ISO heaped)			
		Light material handling bucket with bolt on cutting edges : 0.6 m ³ (0.8 yd ³ : ISO heaped)	□		

Note: ● Standard equipment □ Optional or special equipment

* : Contact your Hitachi dealer for further information.

** : ROPS (Roll Over Protective Structure) Conforms to ISO 3471;1994.

*** : FOPS (Falling Objects Protective Structure) Conforms to ISO 3449; 1992 Level II.



ENGINE

Model	Kubota D1503-DI-T-K2A
Type	4-cycle water-cooled, direct injection
Aspiration	Turbocharger
No. of cylinders	3
Rated power	
DIN 6 271, net	27.2 kW (37 PS) at 2 500 min ⁻¹ (2 500 rpm)
SAE J1349, net	27.2 kW (36 hp) at 2 500 min ⁻¹ (2 500 rpm)
Bore and stroke	83 mm (3.27") x 92.4 mm (3.64")
Piston displacement	1.499 L (91.4 in ³)
Electrical system	12 volt with 0.48 kW, 40 A alternator
Starting system	12 V x 1.4 kW electric motor.
Batteries	1 x 12 V / 490 CCA, 123-min. rated reserve
Air cleaner	Single stage dry type with restriction indicator



POWER TRAIN

Transmission	Hydrostatic transmission automatically controls power and speed with electrically controlled.
Travel speed* : km/h (mph)	
	Forward & Reverse
Low - hold	8 (5.0)
Travel range	15 (9.3)
	* With 15.5 / 60-18-8PR (L2) tires



AXLE AND FINAL DRIVE

Drive system	Four-wheel drive system
Front & rear axle	Semi-floating
	Front : fixed to the front frame
	Rear : Center pivot
Reduction and differential gear	conventional
Oscillation angle	±8° ; total 16°
Final drives	Heavy duty, planetary final drive



TIRES (tubeless, nylon body)

Standard	15.5/60-18-8PR (L2)
----------------	---------------------



BRAKES

Service brakes	Inboard mounted fully hydraulic 4 wheel wet disk.
Parking brake	Spring applied hydraulic released wet disk.



STEERING SYSTEM

Type	Articulated frame steering
Steering mechanism	Full hydraulic power steering with orbitrol
Steering angle	Each direction 41° ; total 82°
Relief pressure	17.2 MPa (175 kgf/cm ² , 2 490 psi)
Cylinders	Double-acting piston type
No. x Bore x Stroke	1 x 55 mm (2.2") x 228 mm (9.0")
Minimum turning radius at the centerline of outside tire	3.22 m (10'7")



HYDRAULIC SYSTEM

Boom and bucket are controlled by mechanical single control lever	
Boom controls	Four position valve ; Raise, hold, lower, float
Bucket controls with automatic bucket return-to-dig control	Three position valve ; Roll back, hold, dump
Main pump (Load & steer)	Gear type 41.2 L/min (10.9 US gal , 9.0 Imp gal/min) @ 2 500 min ⁻¹ (rpm) at 20.6 MPa (210 kgf/cm ² , 2 990 psi)
Relief pressure setting	20.6 MPa (210 kgf/cm ² , 2 990 psi)
Hydraulic cylinders	
Type	Two boom and one bucket, double acting type
No. x Bore x Stroke	Boom : 2 x 65 mm (2.6") x 593 mm (23.3")
	Bucket : 1 x 70 mm (2.8") x 431 mm (17.0")
Filters	Full-flow 15 micron return filter in reservoir
Hydraulic cycle times	
Lift boom Raise	5.0 s
Lower	3.2 s
Bucket dump	1.2 s



SERVICE REFILL CAPACITIES

Fuel tank	50 L (13.2 US gal, 11 Imp gal)
Engine coolant	6.1 L (1.6 US gal, 1.3 Imp gal)
Engine oil	5.6 L (1.5 US gal, 1.2 Imp gal)
Front axle differential & wheel hubs	4.5 L (1.2 US gal, 1.0 Imp gal)
Rear axle differential & wheel hubs	4.5 L (1.2 US gal, 1.0 Imp gal)
Hydraulic reservoir	42 L (11.1 US gal, 9.2 Imp gal)



DIMENSIONS

Bucket type			Standard boom				High-lift boom
			General purpose	Light material handling	Light material handling	Wide(dairy&livestock)	General purpose
			With bolt-on cutting edges	With bolt-on cutting edges	With bolt-on cutting edges	With bolt-on cutting edges	With bolt-on cutting edges
Bucket capacity	ISO heaped	m ³ (yd ³)	0.5 (0.7)	0.6 (0.8)	0.7 (0.9)	0.8 (1.0)	
	ISO struck	m ³ (yd ³)	0.42 (0.5)	0.52 (0.7)	0.6 (0.8)	0.65 (0.9)	
Bucket width		mm (ft-in)	1 690 (5'7")	1 690 (5'7")	1 690 (5'7")	1 890 (6'2")	
Working range							
Dump clearance 45 degree, full height		mm (ft-in)	2 445 (8'0")	2 390 (7'10")	2 305 (7'7")	2 305 (7'7")	
Reach, 45 degree dump, full height		mm (ft-in)	845 (2'9")	900 (2'11")	985 (3'3")	985 (3'3")	
Reach, 45 degree dump, 7 ft (2.13 m) clearance		mm (ft-in)	1 120 (3'8")	1 135 (3'9")	1 150 (3'9")	1 150 (3'9")	
Digging depth (horizontal digging angle)		mm (ft-in)	50 (2.0")	50 (2.0")	50 (2.0")	50 (2.0")	
Overall height, bucket on ground(with FRP canopy)		mm (ft-in)	2 495 (8'2")	2 495 (8'2")	2 495 (8'2")	2 495 (8'2")	2 495 (8'2")
Overall height, bucket on ground(with ROPS canopy)		mm (ft-in)	2 630 (8'8")	2 630 (8'8")	2 630 (8'8")	2 630 (8'8")	
Overall height, bucket on ground(with Steel cab)		mm (ft-in)	2 540 (8'4")	2 540 (8'4")	2 540 (8'4")	2 540 (8'4")	
Overall operating height		mm (ft-in)	3 795 (12'5")	3 865 (12'8")	3 895 (12'9")	3 895 (12'9")	
Overall length (Bucket on ground)		mm (ft-in)	4 425 (14'6")	4 505 (14'9")	4 625 (15'2")	4 625 (15'2")	
Loader clearance circle, bucket in carry position		mm (ft-in)	3 845 (12'7")	3 865 (12'8")	3 900 (12'10")	3 985 (13'1")	
Static tipping load *	Straight	kgf (lbf)	2 060 (4 540)	2 040 (4 500)	2 000 (4 410)	1 980 (4 370)	
	Full 41 degree turn	kgf (lbf)	1 700 (3 750)	1 680 (3 700)	1 640 (3 620)	1 630 (3 590)	
Breakout force		kN	36	31	26	26	
		kgf (lbf)	3 650 (8 050)	3 200 (7 050)	2 650 (5 840)	2 650 (5 840)	
Operating weight *		kgf (lbf)	3 265 (7 200)	3 280 (7 230)	3 300 (7 280)	3 320 (7 320)	

Bucket type			Standard boom with quick-coupler			
			General purpose	Light material handling	Light material handling	Wide(dairy&livestock)
			With bolt-on cutting edges	With bolt-on cutting edges	With bolt-on cutting edges	With bolt-on cutting edges
Bucket capacity	ISO heaped	m ³ (yd ³)	0.5 (0.7)	0.6 (0.8)	0.7 (0.9)	0.8 (1.0)
	ISO struck	m ³ (yd ³)	0.42 (0.5)	0.52 (0.7)	0.6 (0.8)	0.65 (0.9)
Bucket width		mm (ft-in)	1 690 (5'7")	1 690 (5'7")	1 690 (5'7")	1 890 (6'2")
Working range						
Dump clearance 45 degree, full height		mm (ft-in)	2 350 (7'9")	2 295 (7'6")	2 210 (7'3")	2 210 (7'3")
Reach, 45 degree dump, full height		mm (ft-in)	940 (3'1")	995 (3'3")	1 080 (3'7")	1 080 (3'7")
Reach, 45 degree dump, 7 ft (2.13 m) clearance		mm (ft-in)	1 145 (3'9")	1 155 (3'9")	1 165 (3'10")	1 165 (3'10")
Digging depth (horizontal digging angle)		mm (ft-in)	50 (2.0")	50 (2.0")	50 (2.0")	50 (2.0")
Overall height, bucket on ground(with FRP canopy)		mm (ft-in)	2 495 (8'2")	2 495 (8'2")	2 495 (8'2")	2 495 (8'2")
Overall height, bucket on ground(with ROPS canopy)		mm (ft-in)	2 630 (8'8")	2 630 (8'8")	2 630 (8'8")	2 630 (8'8")
Overall height, bucket on ground(with Steel cab)		mm (ft-in)	2 540 (8'4")	2 540 (8'4")	2 540 (8'4")	2 540 (8'4")
Overall operating height		mm (ft-in)	3 885 (12'9")	3 955 (12'12")	3 990 (13'1")	3 990 (13'1")
Overall length (Bucket on ground)		mm (ft-in)	4 560 (14'12")	4 640 (15'3")	4 760 (15'7")	4 760 (15'7")
Loader clearance circle, bucket in carry position		mm (ft-in)	3 880 (12'9")	3 905 (12'10")	3 935 (12'11")	4 025 (13'2")
Static tipping load *	Straight	kgf (lbf)	1 900 (4 190)	1 880 (4 140)	1 830 (4 030)	1 820 (4 010)
	Full 41 degree turn	kgf (lbf)	1 530 (3 370)	1 510 (3 330)	1 480 (3 260)	1 470 (3 240)
Breakout force		kN	28	25	22	21
		kgf (lbf)	2 850 (6 280)	2 550 (5 620)	2 200 (4 850)	2 150 (4 740)
Operating weight *		kgf (lbf)	3 350 (7 390)	3 365 (7 420)	3 385 (7 460)	3 400 (7 500)

Notes: 1. All dimensions, weight and performance data based on ISO 6746-1:1987, ISO 7131:1997 and ISO 7546:1983

2. Static tipping load and operating weight marked with * include 15.5/60-18-8PR (L2) tires (no ballast) with lubricants, coolant, full fuel tank and operator. Machine stability and operating weight depend on counterweight, tire size and other attachments.



WEIGHT CHANGES

Tires and Options	Change in operating weight		Change in tipping load			
			Straight		Full turn	
	kg	lb	kg	lb	kg	lb
Steel cab (in lieu of FRP roof canopy)	3 440	7 584	2 220	4 894	1 840	4 056
ROPS canopy (in lieu of FRP roof canopy)	3 355	7 396	2 200	4 850	1 820	4 012
Canopy with front curved glass (add to FRP roof canopy)	3 315	7 308	2 090	4 608	1 730	3 814
Vinyl cab with front glass (add to FRP roof canopy)	3 325	7 330	2 100	4 630	1 740	3 836
Lumber and pallet fork (pin on type)	3 255	7 176	1 600	3 527	1 320	2 910
Lumber and pallet fork (for quick coupler)	3 340	7 363	1 510	3 329	1 230	2 712
Manure fork (pin on type)						
Manure fork (for quick coupler)	3 295	7 264	1 410	3 108	1 160	2 557
Roll grab (pin on type)						
Roll grab (for quick coupler)	3 345	7 374	1 330	2 932	1 090	2 403



BUCKET SELECTION GUIDE

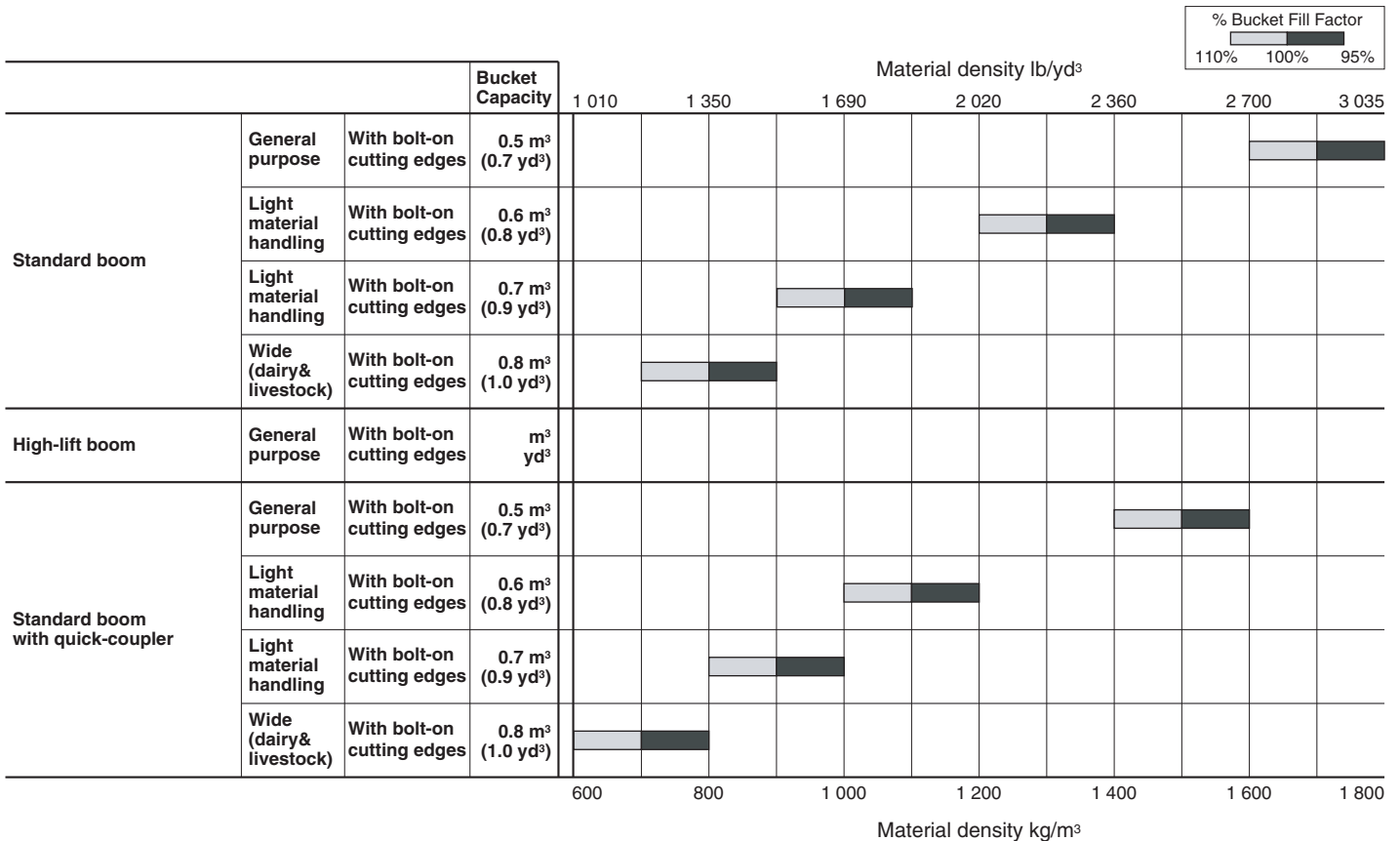

 **Hitachi Construction Machinery Co., Ltd.**

Head Office: 5-1 Koraku 2-chome, Bunkyo-ku,
Tokyo 112-8563, Japan

Telephone: (03)3830-8050

Facsimile: (03)3830-8202

*These specifications are subject to change without notice.
Illustrations and photos show the standard models, and may or may not include optional
equipment, accessories, and all standard equipment with some differences in color and features.*

KL-E098P

'02.06 (KA/KA, MT₃)