

HITACHI

NEW
SuperEX
EX100WD

Rated engine HP

Traveling: 81 kW (110 PS)

Digging: 57 kW (78 PS)

Operating weight: 10 700 kg (23 600 lb)

Bucket capacity

PCSA heaped: 0.19—0.59 m³ (0.25—0.77 yd³)

CECE heaped: 0.17—0.50 m³



Model shown may include options.

Tough Performance Counts on Tough Job Sites

● **The EX100WD Hitachi Wheel Hydraulic Excavator:** This machine on wheels runs fast, and so does the job at hand ... with marked operating efficiency.

Notice its inching and bucket positioning ability, along with the light, swift footwork of a town car. They yield a short cycle time for increased production — Hitachi's top consideration for a wheel hydraulic excavator. The Hitachi EX100WD.

① **Improved Digging Performance for Big Production:** Pump delivery flow is controlled according to loading conditions to increase digging and dumping speeds. Production is increased by 3% without increasing fuel consumption. In other words, fuel consumption is cut by 3% (compared to our conventional model).

② **Rapid, Smooth Leveling and Slope Finishing:** Quick, smooth leveling allows efficient stripping, backfilling, and leveling in road construction and sewerage works.

● **Rapid Response:** The arm moves precisely according to level stroke. This enables efficient gravel spreading in civil engineering work and road building.

③ **Improved Inching in Low Speed Range:** Inching is further improved, easing travel even in confined areas, precision operation during traveling, and bucket positioning.

④ **Work Mode Selector:** The operator can select an optimum work mode out of four modes — general purpose, grading, trenching and precision — at the touch of a button.

● **Acceleration Pedal Boosts Digging Efficiency:** The working speeds of the front attachment and special attachment can be freely controlled with the acceleration pedal. The pedal depression range can be adjusted to reduce fuel consumption.

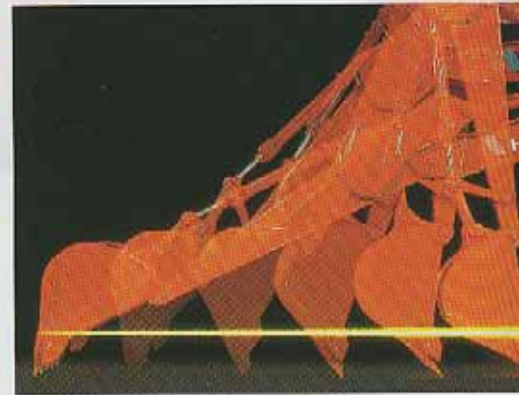
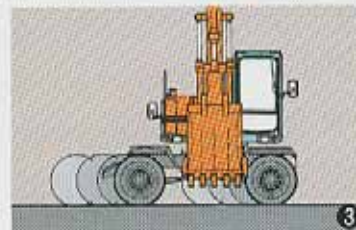

- Improved E-P (Engine-Pump) control for upgraded performance and increased fuel savings.
- Positive combined operation and smooth control made easy with the ELLE system.
- Improved shockless valve dampens shocks at stops of the front attachment.
- Swing dampener mechanism prevents coasting at stops of swing.
- Auto Idling reduces fuel consumption when the machine is not in use.

Footwork of a Town Car

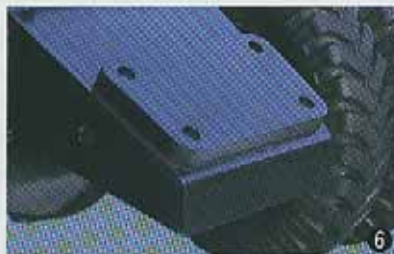
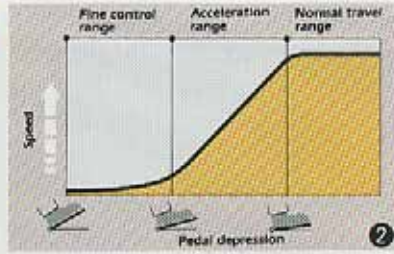

The tires shown in Photos 4, 5 and 6 are available as an option.

1 Improved E-P Control of Travel: The E mode effectively helps reduce fuel consumption. The P mode activates the speed-sensing control and load-sensing system for efficient use of engine horsepower according to travel conditions. Either mode can be selected according to job conditions.

2 Acceleration Pedal Control: Quick starts, smooth acceleration and deceleration, and positive stops all by acceleration pedal control: this pedal responds rapidly to the operator's will. What's more, its generous fine control range eases inching.

3 Hi/Lo Range: The High speed range gives quick starts, smooth acceleration, and powerful slope climbing. The Low speed range allows smooth starts and stops with less shock.

4 Ram Lock Mechanism: The ram lock mechanism is unlocked to absorb shocks during travel, and interlocked with the working brake for stable digging with less shock.

5 Four Wheel Drive Mobility on Rough Terrain: Four wheel drive provides smooth starts and powerful travel with ample traction force, especially on rough terrain and off-road areas.

6 Rubber Damper to Absorb Front Shocks: The rubber damper at the front absorbs shocks from the bucket during travel, further enhancing mobility.



Riding Comfort



❶ **Comfort-designed Suspension Seat:** Seating comfort is further enhanced through the use of a cold-foam suspension seat.

❷ **Sliding Cockpit:** The operator seat, called the sliding cockpit, glides separately or together with control levers and monitor panel, adjusting to the proportions of any operator.

❸ **Ergonomically Designed Control Levers:** Lever control force is reduced by 20% to 40% in the back-and-forth direction (compared to that of conventional model). This allows light lever handling.

❹ **Sleek Steering Column:** Levers, switches and meters are logically grouped at the sleek steering column for easy steering and added visibility.

❺ **Wing Console Gives Easy Access:** The left console can be lifted out of the way to permit easy, unobstructed access to the operator's seat without disturbing the control levers.

❻ **Air Conditioner (Option):** An air conditioner, using a freon substitute, maintains operator comfort all year around, increasing operating efficiency.

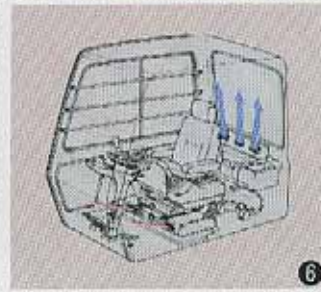
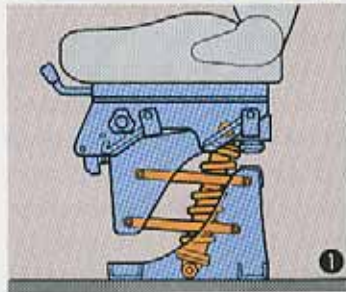

- Easy-to-read curved monitor and finger-touch switches
- Window washer and intermittent wiper keep the front window clean.
- Spring-assisted front window for easy in-cab storage.
- Automobile-type AM radio with auto-tuning and digital clock



Dependable Design

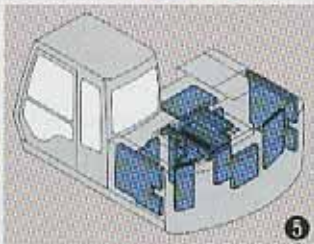
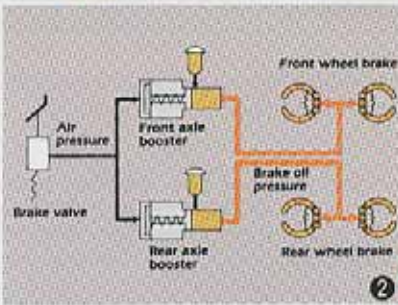

1 Seat Belt Provided as Standard

2 Twin-booster Type Brake: The braking system has two independent boosters (front and rear). If any trouble arises at the front or rear axle, this twin-booster type brake brings the machine to a full stop.

3 Air Drier to Eliminate Moisture in the Pneumatic Line: To prevent problem with moisture freezing in the brake pneumatic circuit, an air drier (dehumidifier) is provided as standard equipment.

4 Dependable Parking Brake: The parking brake is applied automatically when the engine stalls. Even after the engine restarts, the brake remains engaged until the forward/reverse lever is shifted.

5 Operator-friendly Low-noise Design:

Operation is quiet: 71 dB (A) in the E mode and 73 dB (A) in the P mode at 7 m away.

6 Large Curved Rear Window: The cab's large, curved rear window provides good rear visibility, further increased by the low-profile engine hood.

- Wave-finned radiator to avoid clogging
- Pilot-control shutoff lever
- Quick warm-up system for pilot circuit to reduce response delay in cold weather
- Hydraulic warm-up control system for engine and hydraulic oil
- Two-line engine stop system
- Swing parking brake
- Bucket clearance adjust mechanism
- Rugged D-section frame skirt



1 Extra Port That Sets Optimum Flow

According to the Attachment: The extra port is a hydraulic source for setting and delivering the optimum flow to the above special attachment.

2 Special Attachment Mode Optionally

Available: The special attachment mode can be selected according to the attachment in use by using the attachment selection switch. This makes combined operation smooth.

SPECIFICATIONS

ENGINE

Model	Isuzu 4BD1T
Type	4-cycle, water-cooled, direct injection
Aspiration	Turbocharged
No. of cylinders	4
Rated flywheel horsepower (DIN 6271, net)	
Traveling	81 kW (110 PS) at 2 500 min ⁻¹ (rpm)
Digging	57 kW (78 PS) at 1 800 min ⁻¹ (rpm)
Rated flywheel horsepower (SAE J1349, net)	
Traveling	81 kW (109 HP) at 2 500 rpm
Digging	57 kW (77 HP) at 1 800 rpm
Maximum torque	314 Nm (32 kgfm, 231 lbf·ft) at 1 800 rpm
Piston displacement	3.86 L (235 in ³)
Bore and stroke	102 mm × 118 mm (4.02" × 4.65")
Starting system	24 V electric motor starting
Batteries	2 × 12 V, 52 AH

HYDRAULIC SYSTEM

ELLE (Electronic Load-sensing Excavation) system designed for maximum job efficiency and precise, smooth control.

- Load-sensing system
- Flow dividing control system
- Work mode selector
 - General-purpose mode / Trenching mode
 - Grading mode / Precision mode

Power selector designed for maximum productivity and fuel savings.

- Engine speed sensing system
 - P (Power) mode / E (Economy) mode
 - L (Low speed) mode / I (Low idle) mode

Main pump	1 variable displacement axial piston pump
Maximum oil flow	1 × 180 L/min (47.0 US gpm, 39.2 Imp gpm)
Steering pump	1 gear pump
Maximum oil flow	42 L/min (11.1 US gpm, 9.2 Imp gpm)
Pilot pump	1 gear pump
Maximum oil flow	42 L/min (11.1 US gpm, 9.2 Imp gpm)

Hydraulic Motors

Travel	1 variable displacement axial piston motor
Swing	1 axial piston motor

Relief Valve Settings

Implement circuit	34.3 MPa (350 kgf/cm ² , 4 980 psi)
Swing circuit	34.5 MPa (355 kgf/cm ² , 4 980 psi)
Travel circuit	35.8 MPa (365 kgf/cm ² , 5 190 psi)
Outrigger circuit	24.5 MPa (250 kgf/cm ² , 3 560 psi)
Pilot circuit	4.9 MPa (50 kgf/cm ² , 710 psi)

Hydraulic Cylinders

High-strength piston rods and tubes. Cylinder cushion mechanisms provided in all cylinders to absorb shocks at stroke ends.

Dimensions

	Qty	Bore	Rod diameter
Boom	2	95 mm (3.74")	70 mm (2.76")
Arm	1	105 mm (4.13")	75 mm (2.95")
Bucket	1	95 mm (3.74")	65 mm (2.56")

Hydraulic Filters

Hydraulic circuits use high-quality hydraulic filters. A suction filter is incorporated in the suction line, and 10 μm full-flow filters in the return line and swing/travel motor drain lines.

CONTROLS

Implement Levers

Pilot controls. Hitachi's original shockless valve and quick warm-up system built in the pilot circuit. Hydraulic warm-up control system for engine and hydraulic oil. Multi selection lever with rotary valve is optionally available for selection of control lever direction.

Implement levers 2

Steering Wheel

Use of the two steering cylinders equalizes clockwise and counter-clockwise steering angles per turns of the steering wheel.

UPPERSTRUCTURE

Revolving Frame

Welded sturdy box construction using, heavy-gauge steel plates for ruggedness. D-section frame for resistance to deformation.

Swing Mechanism

Axial piston motor with planetary reduction gear is bathed in oil. Swing circle is single-row, shear-type ball bearing with induction-hardened internal gear. Internal gear and pinion gear are immersed in lubricant. Swing parking brake is spring-set/hydraulic-released disc type. Swing dampener valve in the swing circuit prevents coasting when stopping swing. Swing cushion valve built in swing motor absorbs shocks when stopping swing.

Swing speed 11.0 min⁻¹ (rpm)

Operator's Cab

Independent roomy cab, 940 mm (37") wide by 1 620 mm (64") high, conforming to ISO* Standards. Reinforced glass windows on 4 sides for visibility. Front windows (upper and lower) are operable and spring-assisted for easy storing in the cab and absorbing shocks during lowering. Adjustable, suspension seat with armrests; movable with or without control levers and monitor panel.

* International Standard Organization

UNDERCARRIAGE

Wheeled-type undercarriage. The frame is of welded, stress-relieved structure. Top-grade materials used for toughness.

Drive system 4 × 4 (4 wheel drive)
Transmission Constant mesh type for high and low speed range.

Travel speed
 Low speed range 0 to 12.7 km/h (7.9 mph),
 forward and reverse
 High speed range 0 to 34.5 km/h (21.4 mph),
 forward and reverse

Max. traction force 60.3 kN (6 150 kgf, 13 600 lbf)
Gradeability 33° (65%)

Steering System

Hydraulically actuated, orbit-roll-type steering system actuates on front wheels through the steering cylinders.

2 steering cylinders
 Bore 60 mm (2.4")
 Rod diameter 25 mm (1")
 Min. turning radius 6 500 mm (21'4")

Brakes

Service brake (foot pedal)	Air-over hydraulic brakes acting at each wheel-internal-expanding shoe type. Brake lines are independent to front wheels and rear wheels
Parking brake (switch)	Spring actuated, air-released, internal-expanding shoe type, acting on horizontal drive shaft.
Digging brake (switch)	Acting at all wheels, horizontal drive shaft and also locks oscillation cylinders for digging operation

Axles

Full-floating front axle is center-pin supported for oscillation. It can be locked by oscillation cylinders. Full-floating rear axle is fixed on the chassis.

Tires

Traction-type tread pattern for offroad use—rough terrain, swampy or sandy ground—generating high traction force with less slippage. Standard 9.00 - 20 - 12 PR x 8

SERVICE REFILL CAPACITIES

	liters	US gal	Imp gal
Fuel tank	250.0	66.1	55.0
Engine coolant	18.4	4.9	4.0
Engine oil	14.7	3.9	3.2
Swing device	4.0	1.1	0.9
Transmission	3.5	0.9	0.8
Differential gear box (front/rear)	6.0/8.0	1.6/2.1	1.3/1.8
Hub reduction gear			
front axle	2 x 1.5	2 x 0.4	2 x 0.33
rear axle	2 x 1.5	2 x 0.4	2 x 0.33
Hydraulic system	132.0	34.9	29.0
Hydraulic tank	69.0	18.2	15.2

BACKHOE ATTACHMENTS

Boom and arms are of welded, full box-section design, 4.27 m (14'0") boom, and 1.96 m (6'5"), 2.26 m (7'5") arms are available.

Bucket is of welded steel structure. Side clearance adjust mechanism provided on the bucket joint bracket.

Buckets [EX100WD-3]

Capacity		Width		No. of teeth	Weight	Recommendation	
PCSA heaped	CECE heaped	Without side cutters	With side cutters			1.96 m (6'5") arm	2.26 m (7'5") arm
0.19 m ³ (0.25 yd ³)	0.17 m ³	450 mm (18")	550 mm (22")	3	240 kg (530 lb)	⊙	⊙
0.30 m ³ (0.39 yd ³)	0.25 m ³	580 mm (23")	700 mm (28")	3	280 kg (620 lb)	⊙	⊙
0.40 m ³ (0.52 yd ³)	0.33 m ³	680 mm (27")	800 mm (31")	4	320 kg (710 lb)	⊙	⊙
0.46 m ³ (0.60 yd ³)	0.40 m ³	850 mm (33")	970 mm (38")	5	370 kg (820 lb)	⊙	⊙
0.55 m ³ (0.72 yd ³)	0.45 m ³	890 mm (35")	1 010 mm (40")	5	390 kg (860 lb)	⊙	○
0.59 m ³ (0.77 yd ³)	0.50 m ³	950 mm (37")	1 070 mm (42")	5	410 kg (900 lb)	○	□
V-shaped bucket: 0.35 m ³				3	370 kg (710 lb)	○	○
Clamshell bucket: 0.30 m ³ , Width 560 mm (22")				6	690 kg (1 520 lb)	⊙	⊙
Slope-finishing blade: Width 1 000 mm (39"), Length 1 600 mm (63")					430 kg (1 050 lb)	◇	◇

- ⊙ Suitable for materials with density of 2 000 kg/m³ (3 370 lb/yd³) or less
- Suitable for materials with density of 1 600 kg/m³ (2 700 lb/yd³) or less
- Suitable for materials with density of 1 100 kg/m³ (1 850 lb/yd³) or less
- ◇ Slope-finishing service
- Not recommended

Buckets [EX100WD-3 Off-set front]

Capacity		Width		No. of teeth	Weight	Recommendation
PCSA heaped	CECE heaped	Without side cutters	With side cutters			EX100WD-3 with off-set front
0.19 m ³ (0.25 cu yd)	0.17 m ³	450 mm (18")	550 mm (22")	3	240 kg (530 lb)	○
0.30 m ³ (0.39 cu yd)	0.25 m ³	580 mm (23")	700 mm (28")	3	280 kg (620 lb)	○
0.40 m ³ (0.52 cu yd)	0.33 m ³	680 mm (27")	800 mm (31")	4	320 kg (710 lb)	○
0.46 m ³ (0.60 cu yd)	0.40 m ³	850 mm (33")	970 mm (38")	5	370 kg (820 lb)	○

- Suitable for materials with density of 2 000 kg/m³ (3 370 lb/cu yd) or less

EX100WD-3

DIMENSIONS

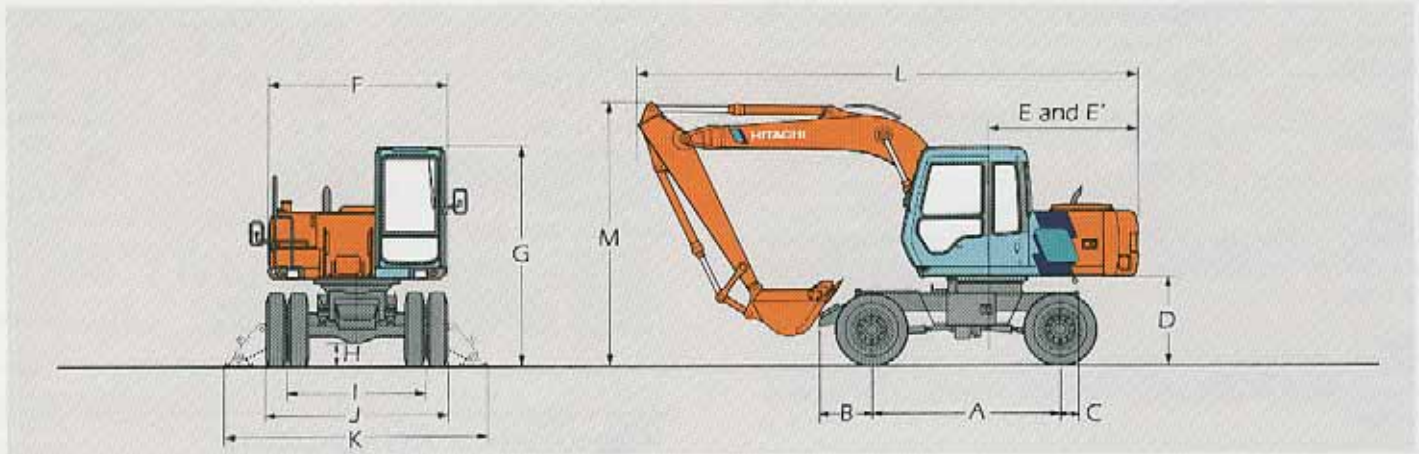

A	Wheel base	2 600 mm (8'6")
B	Center of front axle to front end	725 mm (2'5")
C	Swing center to outrigger end	2 005 mm (6'7")
D	Counterweight clearance	1 190 mm (3'11")
E	Rear-end swing radius	2 130 mm (7'0")
E'	Rear-end length	2 100 mm (6'11")
F	Overall width of upperstructure	2 470 mm (8'1")
G	Overall height of cab	3 020 mm (9'11")
H	Min. ground clearance	325 mm (1'1")
I	Tread	1 895 mm (6'3")
J	Overall width (Undercarriage width)	2 460 mm (8'1")
K	Overall width of outrigger extended	3 490 mm (11'5")
L	Overall length	7 110 mm (23'4") with 1.96 m (6'5") arm 6 945 mm (22'9") with 2.26 m (7'5") arm
M	Overall height of boom	3 400 mm (11'2") with 1.96 m (6'5") arm 3 610 mm (11'10") with 2.26 m (7'5") arm

WORKING RANGES

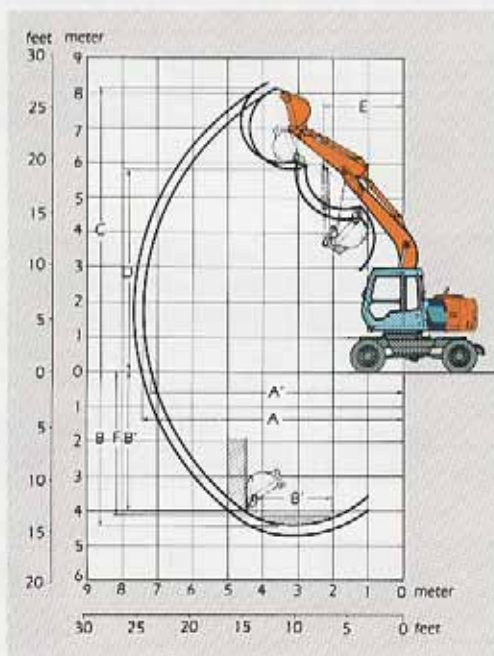

	Arm length	1.96 m (6'5")	2.26 m (7'5")
A	Max. digging reach	7 430 mm (24'5")	7 700 mm (25'3")
A'	Max. digging reach (on ground)	7 210 mm (23'7")	7 500 mm (24'7")
B	Max. digging depth	4 460 mm (14'8")	4 760 mm (15'7")
B'	Max. digging depth (B' level)	4 200 mm (13'9")	4 530 mm (14'10")
C	Max. cutting height	8 160 mm (26'9")	8 330 mm (27'4")
D	Max. dumping height	5 770 mm (18'11")	5 930 mm (19'5")
E	Min. swing radius	2 370 mm (7'9")	2 400 mm (7'10")
F	Max. vertical wall	4 000 mm (13'1")	4 300 mm (14'1")
	Bucket digging force	78.5 kN (8 000 kgf, 17 600 lbf)	78.5 kN (8 000 kgf, 17 600 lbf)
	Arm crowd force	57.9 kN (5 900 kgf, 13 000 lbf)	53.0 kN (5 400 kgf, 11 900 lbf)

EX100WD-3 Off-set front

DIMENSIONS

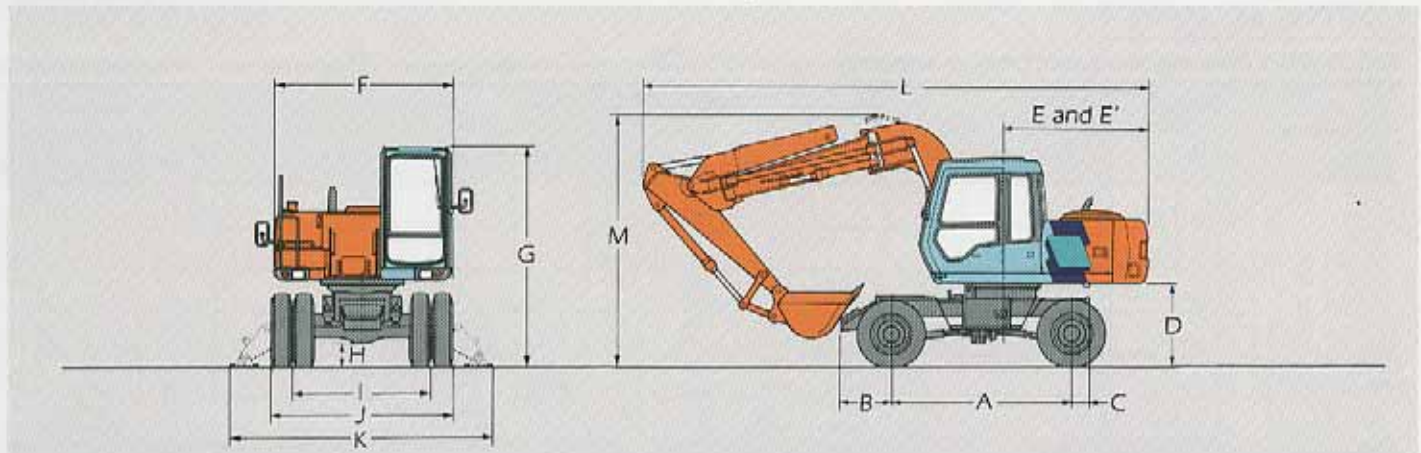

A	Wheel base	2 600 mm (8'6")
B	Center of front axle to front end	725 mm (2'5")
C	Swing center to outrigger end	2 005 mm (6'7")
D	Counterweight clearance	1 190 mm (3'11")
E	Rear-end swing radius	2 130 mm (7'0")
E'	Rear-end length	2 100 mm (6'11")
F	Overall width of upperstructure	2 470 mm (8'1")
G	Overall height of cab	3 020 mm (9'11")
H	Min. ground clearance	325 mm (1'1")
I	Tread	1 895 mm (6'3")
J	Overall width (Undercarriage width)	2 460 mm (8'1")
K	Overall width of outrigger extended	3 490 mm (11'5")
L	Overall length	7 270 mm (23'10") with 1.96 m (6'5") arm
M	Overall height of boom	3 635 mm (11'11") with 1.96 m (6'5") arm

WORKING RANGES

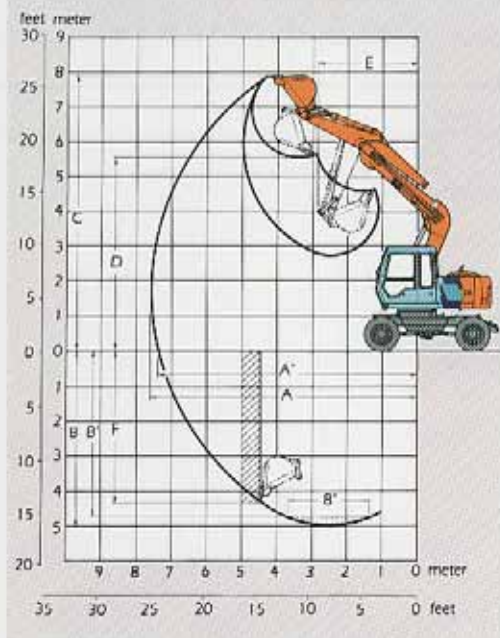

Arm length	1.96 m (6'5")			
	Off-set distance	0 m	Max.	Right-side priority position
A	Max. digging reach	7 620 mm (25'0")	7 090 mm (23'3")	6 850 mm (22'6")
A'	Max. digging reach (on ground)	7 400 mm (24'3")	6 850 mm (22'6")	6 610 mm (21'8")
B	Max. digging depth	5 010 mm (16'5")	4 470 mm (14'8")	4 220 mm (13'10")
B'	Max. digging depth (8' level)	4 730 mm (15'6")	4 190 mm (13'9")	3 950 mm (13'0")
C	Max. cutting height	7 910 mm (25'11")	7 580 mm (24'10")	7 440 mm (24'5")
D	Max. dumping height	5 550 mm (18'3")	5 210 mm (17'1")	5 070 mm (16'8")
E	Min. swing radius	2 910 mm (9'7")	2 460 mm (8'1")	2 270 mm (7'5")
F	Max. vertical wall	4 350 mm (14'3")	3 810 mm (12'6")	3 590 mm (11'9")
G	Left side off-set distance	—	1 300 mm (4'3")	1 070 mm (3'6")
H	Right side off-set distance	—	1 540 mm (5'1")	1 770 mm (5'10")
	Bucket digging force	78.5 kN (8 000 kgf, 17 600 lbf)		
	Arm crowd force	57.9 kN (5 900 kgf, 13 000 lbf)		



LIFTING CAPACITIES

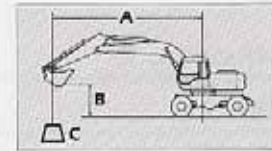

A: Load radius
B: Load point height
C: Lifting capacity

METRIC MEASURE

EX100WD-3 (Not equipped with rear outriggers)

Rating over-side or 360 degrees

Rating over-rear

Unit: 1 000 kg (1 000 lb)

Conditions	Load point height m (ft in)	Load radius										At max. reach						
		2 (6'7")		3 (9'10")		4 (13'1")		5 (16'5")		6 (19'8")		7 (23'0")		m (ft in)	kg (lb)	kg (lb)		
Boom 4.27 m (14'0") Arm 1.96 m (6'5") Bucket PCSA: 0.46 m ³ (0.60 yd ³) CECE: 0.40 m ³ Tires 9.00-20-12PR, duals	6 (19'8")					*2.48 (5.47)	*2.48 (5.47)								*1.19 (2.62)	*1.19 (2.62)	5.41 (11'9")	
	5 (16'5")					*2.51 (5.53)	*2.51 (5.53)	1.78 (3.92)	2.15 (4.74)						*1.11 (2.45)	*1.11 (2.45)	6.19 (13'6")	
	4 (13'1")			*3.34 (7.36)	*3.34 (7.36)	2.58 (5.69)	*2.88 (6.35)	1.75 (3.86)	2.11 (4.65)						*1.09 (2.40)	*1.09 (2.40)	6.69 (14'5")	
	3 (9'10")			3.88 (8.56)	*4.60 (10.14)	2.44 (5.38)	2.94 (6.48)	1.68 (3.70)	2.04 (4.50)	1.20 (2.65)	1.48 (3.26)				0.98 (2.16)	*1.10 (2.43)	6.98 (15'2")	
	2 (6'7")			3.56 (7.85)	4.35 (9.59)	2.29 (5.05)	2.79 (6.15)	1.60 (3.53)	1.97 (4.34)	1.16 (2.56)	1.45 (3.20)				0.93 (2.05)	*1.14 (2.50)	7.10 (15'5")	
	1 (3'3")			3.41 (7.52)	4.19 (9.24)	2.18 (4.81)	2.68 (5.91)	1.54 (3.40)	1.90 (4.19)	1.13 (2.49)	1.42 (3.13)				0.92 (2.03)	1.15 (2.54)	7.04 (15'5")	
	0 (Ground)			3.36 (7.41)	4.14 (9.13)	2.12 (4.62)	2.62 (5.78)	1.50 (3.31)	1.86 (4.10)						0.96 (2.12)	1.20 (2.65)	6.82 (15'0")	
	-1 (-3'3")	*4.96 (10.94)	*4.96 (10.94)	3.36 (7.41)	4.13 (9.11)	2.11 (4.65)	2.60 (5.72)	1.49 (3.29)	1.85 (4.08)						1.07 (2.36)	1.33 (2.93)	6.40 (14'1")	
	-2 (-6'7")	7.22 (15.92)	*8.14 (17.95)	3.40 (7.50)	4.18 (9.22)	2.14 (4.72)	2.63 (5.80)								1.30 (2.87)	1.60 (3.53)	5.74 (12'7")	
	-3 (-9'10")			3.50 (7.72)	4.30 (9.48)													
	Boom 4.27 m (14'0") Arm 2.26 m (7'5") Bucket PCSA: 0.46 m ³ (0.60 yd ³) CECE: 0.40 m ³ Tires 9.00-20-12PR, duals	6 (19'8")					*2.50 (5.51)	*2.50 (5.51)								*1.09 (2.40)	*1.09 (2.40)	5.75 (12'6")
		5 (16'5")					*2.57 (5.67)	*2.57 (5.67)	1.79 (3.95)	2.16 (4.76)						*1.02 (2.25)	*1.02 (2.25)	6.49 (14'3")
4 (13'1")						2.61 (5.76)	*2.96 (6.53)	1.75 (3.86)	2.12 (4.67)	1.22 (2.69)	1.51 (3.33)			*0.99 (2.18)	*0.99 (2.18)	6.97 (15'2")		
3 (9'10")				3.96 (8.73)	*4.60 (10.14)	2.50 (5.51)	2.96 (6.53)	1.68 (3.70)	2.04 (4.50)	1.19 (2.62)	1.48 (3.26)			0.89 (1.96)	*1.00 (2.21)	7.25 (15'9")		
2 (6'7")				3.61 (7.96)	4.39 (9.68)	2.30 (5.07)	2.80 (6.17)	1.59 (3.51)	1.96 (4.32)	1.15 (2.54)	1.44 (3.18)			0.84 (1.85)	*1.03 (2.27)	7.37 (16'2")		
1 (3'3")				3.39 (7.47)	4.17 (9.19)	2.17 (4.78)	2.67 (5.89)	1.51 (3.33)	1.88 (4.15)	1.11 (2.45)	1.40 (3.09)			0.83 (1.83)	1.06 (2.34)	7.32 (16'0")		
0 (Ground)				3.31 (7.30)	4.08 (9.08)	2.09 (4.61)	2.59 (5.71)	1.47 (3.24)	1.83 (4.04)	1.08 (2.38)	1.37 (3.02)			0.86 (1.90)	1.09 (2.40)	7.12 (15'6")		
-1 (-3'3")		*4.92 (10.85)	*4.92 (10.85)	3.29 (7.25)	4.07 (8.97)	2.06 (4.54)	2.56 (5.64)	1.45 (3.20)	1.81 (4.00)					0.95 (2.09)	1.20 (2.65)	6.73 (14'8")		
-2 (-6'7")		7.07 (15.60)	*7.71 (17.00)	3.32 (7.32)	4.10 (9.04)	2.08 (4.59)	2.58 (5.69)	1.47 (3.24)	1.83 (4.04)					1.13 (2.47)	1.41 (3.11)	6.12 (13'5")		
-3 (-9'10")		*6.65 (14.66)	*6.65 (14.66)	3.42 (7.54)	4.20 (9.26)	2.16 (4.76)	2.66 (5.87)							1.52 (3.35)	1.86 (4.10)	5.20 (11'5")		
-4 (-13'1")																		

- Notes:
1. Ratings are based on SAE J1097.
 2. Lifting capacity of the Super EX Series does not exceed 75% of tipping load with the machine on firm, level ground or 87% of full hydraulic capacity.
 3. The load point is a hook (not standard equipment) loaded on the back of the bucket.
 4. *Indicates load limited by hydraulic capacity.

METRIC MEASURE

EX100WD-3 (with rear outriggers on ground)

Rating over-side or 360 degrees Rating over-rear Unit: 1 000 kg (1 000 lb)

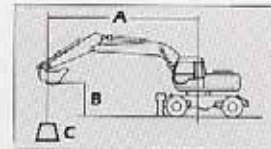

A: Load radius
B: Load point height
C: Lifting capacity

Conditions	Load point height m (ft in)	Load radius										At max. reach						
		2 (6'7")		3 (9'10")		4 (13'1")		5 (16'5")		6 (19'8")		7 (23'0")		m (ft in)				
Boom 4.27 m (14'0") Arm 1.96 m (6'5") Bucket PCSA: 0.46 m ³ (0.60 yd ³) CECE: 0.40 m ³ Tires 9.00-20-12PR, duals	6 (19'8")					*2.48 (5.47)	*2.48 (5.47)									*1.19 (2.62)	*1.19 (2.62)	5.41 (17'9")
	5 (16'5")					*2.51 (5.53)	*2.51 (5.53)	*2.49 (5.49)	*2.49 (5.49)							*1.11 (2.45)	*1.11 (2.45)	6.19 (20'4")
	4 (13'1")			*3.34 (7.36)	*3.34 (7.36)	*2.88 (6.35)	*2.88 (6.35)	*2.67 (5.89)	*2.67 (5.89)							*1.09 (2.40)	*1.09 (2.40)	6.69 (21'11")
	3 (9'10")			*4.60 (10.14)	*4.60 (10.14)	*3.46 (7.63)	*3.46 (7.63)	2.59 (5.71)	*2.95 (6.50)	1.89 (4.17)	*1.99 (4.39)					*1.10 (2.43)	*1.10 (2.43)	6.98 (22'11")
	2 (6'7")			5.81 (12.81)	*5.86 (12.92)	3.60 (7.94)	*4.09 (9.02)	2.51 (5.53)	*3.28 (7.23)	1.86 (4.10)	*2.68 (5.91)					*1.14 (2.51)	*1.14 (2.51)	7.10 (23'4")
	1 (3'3")			*5.48 (12.08)	*5.48 (12.08)	3.48 (7.67)	*4.56 (10.05)	2.44 (5.38)	*3.56 (7.85)	1.82 (4.01)	*2.72 (6.00)					*1.21 (2.67)	*1.21 (2.67)	7.04 (23'1")
	0 (Ground)			5.57 (12.28)	*6.67 (14.71)	3.41 (7.52)	*4.79 (10.56)	2.40 (5.29)	*3.72 (8.20)							*1.33 (2.93)	*1.33 (2.93)	6.82 (22'5")
	-1 (-3'3")	*4.96 (10.94)	*4.96 (10.94)	5.57 (12.28)	*6.43 (14.18)	3.40 (7.50)	*4.75 (10.47)	2.39 (5.27)	*3.65 (8.05)							*1.52 (3.35)	*1.52 (3.35)	6.40 (21'0")
	-2 (-6'7")	*8.14 (17.95)	*8.14 (17.95)	5.62 (12.39)	*5.81 (12.81)	3.43 (7.56)	*4.33 (9.55)									*1.85 (4.08)	*1.85 (4.08)	5.74 (18'10")
	-3 (-9'10")			*4.53 (9.99)	*4.53 (9.99)											*4.53 (9.99)	*4.53 (9.99)	3.00 (9'10")
Boom 4.27 m (14'0") Arm 2.26 m (7'5") Bucket PCSA: 0.46 m ³ (0.60 yd ³) CECE: 0.40 m ³ Tires 9.00-20-12PR, duals	6 (19'8")					*2.50 (5.51)	*2.50 (5.51)									*1.09 (2.40)	*1.09 (2.40)	5.75 (18'10")
	5 (16'5")					*2.57 (5.67)	*2.57 (5.67)	*2.59 (5.71)	*2.59 (5.71)							*1.02 (2.25)	*1.02 (2.25)	6.49 (21'4")
	4 (13'1")					*2.96 (6.53)	*2.96 (6.53)	2.68 (5.91)	*2.74 (6.04)	*1.70 (3.75)	*1.70 (3.75)				*0.99 (2.19)	*0.99 (2.19)	6.97 (22'10")	
	3 (9'10")			*4.60 (10.14)	*4.60 (10.14)	*3.55 (7.83)	*3.55 (7.83)	2.60 (5.73)	*3.04 (6.70)	1.89 (4.17)	*2.63 (5.80)				*1.00 (2.21)	*1.00 (2.21)	7.25 (23'9")	
	2 (6'7")			5.87 (12.94)	*5.91 (13.03)	3.61 (7.96)	*4.20 (9.26)	2.51 (5.53)	*3.38 (7.45)	1.84 (4.06)	*2.93 (6.46)				*1.03 (2.27)	*1.03 (2.27)	7.37 (24'2")	
	1 (3'3")			5.62 (12.39)	*6.70 (14.77)	3.47 (7.65)	*4.71 (10.39)	2.43 (5.36)	*3.68 (8.11)	1.80 (3.97)	*3.07 (6.77)				*1.10 (2.43)	*1.10 (2.43)	7.32 (24'0")	
	0 (Ground)			5.52 (12.17)	*6.90 (15.21)	3.38 (7.45)	*4.95 (10.91)	2.37 (5.23)	*3.84 (8.47)	1.78 (3.92)	*3.10 (6.84)					*1.21 (2.67)	*1.21 (2.67)	7.12 (23'4")
	-1 (-3'3")	*4.92 (10.85)	*4.92 (10.85)	5.50 (12.13)	*6.66 (14.69)	3.35 (7.39)	*4.91 (10.83)	2.35 (5.18)	*3.79 (8.36)							*1.38 (3.04)	*1.38 (3.04)	6.73 (22'1")
	-2 (-6'7")	*7.71 (17.00)	*7.71 (17.00)	5.54 (12.22)	*6.03 (13.30)	3.37 (7.43)	*4.51 (9.94)	2.37 (5.23)	*3.37 (7.43)							*1.65 (3.64)	*1.65 (3.64)	6.12 (20'1")
	-3 (-9'10")	*6.65 (14.66)	*6.65 (14.66)	*4.85 (10.69)	*4.85 (10.69)	3.40 (7.63)	*3.50 (7.72)									*2.18 (4.81)	*2.18 (4.81)	5.20 (17'1")
-4 (-13'1")																		

- Notes: 1. Ratings are based on SAE J1097.
2. Lifting capacity of the Super EX Series does not exceed 75% of tipping load with the machine on firm, level ground or 87% of full hydraulic capacity.
3. The load point is a hook (not standard equipment) loaded on the back of the bucket.
4. *Indicates load limited by hydraulic capacity.

METRIC MEASURE

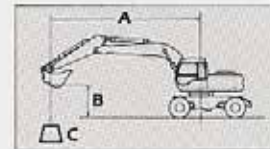

A: Load radius
B: Load point height
C: Lifting capacity

EX100WD-3 with Off-set front (Not equipped with rear outriggers) Rating over-side or 360 degrees Rating over-rear Unit: 1 000 lb

Conditions	Load point height m (ft in)	Load radius										At max. reach						
		2 (6'7")		3 (9'10")		4 (13'1")		5 (16'5")		6 (19'8")		7 (23'0")				m (ft in)		
Arm 1.96 m (6'5") Bucket PCSA: 0.46 m ³ (0.60 cu yd) CECE: 0.40 m ³ Tires 9.00-20-12PR, duals	5 (16'5")							1.71 (3.77)	*1.91 (4.21)							*0.77 (1.70)	*0.77 (1.70)	6.38 (20'11")
	4 (13'1")					*2.15 (4.74)	*2.15 (4.74)	1.64 (3.62)	*2.06 (4.54)							*0.74 (1.63)	*0.74 (1.63)	6.87 (22'6")
	3 (9'10")			3.66 (8.07)	*3.73 (8.22)	2.28 (5.03)	*2.75 (6.06)	1.52 (3.35)	*2.36 (5.20)	1.03 (2.27)	2.21 (4.87)					*0.74 (1.63)	*0.74 (1.63)	7.16 (23'6")
	2 (6'7")					2.03 (4.48)	*3.42 (7.54)	1.39 (3.06)	*2.73 (6.02)	0.96 (2.12)	2.14 (4.72)					*0.70 (1.54)	*0.76 (1.68)	7.28 (23'11")
	1 (3'3")					1.83 (4.04)	*3.98 (8.78)	1.27 (2.80)	2.86 (6.31)	0.90 (1.98)	2.07 (4.56)					*0.68 (1.50)	*0.80 (1.76)	7.23 (23'9")
	0 (Ground)			2.77 (6.11)	*6.20 (13.7)	1.73 (3.81)	4.09 (9.02)	1.20 (2.65)	2.77 (6.11)	0.87 (1.92)	2.03 (4.48)					*0.70 (1.54)	*0.87 (1.92)	7.03 (23'1")
	-1 (-3'3")	*4.97 (11.0)	*4.97 (11.0)	2.76 (6.09)	*6.20 (13.7)	1.70 (3.75)	4.05 (8.93)	1.18 (2.60)	2.74 (6.04)							*0.79 (1.74)	*0.99 (2.18)	6.63 (21'9")
	-2 (-6'7")	6.24 (13.8)	*8.23 (18.1)	2.83 (6.24)	*5.93 (13.1)	1.74 (3.84)	4.36 (9.61)	1.23 (2.71)	2.80 (6.17)							*0.97 (2.14)	*1.18 (2.60)	6.01 (19'9")
	-3 (-9'10")	6.51 (14.4)	*7.57 (16.7)	3.01 (6.64)	*5.24 (11.6)	1.89 (4.17)	*3.74 (8.25)									1.39 (3.06)	*1.55 (3.42)	5.06 (16'7")

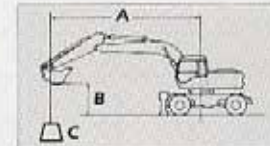

A: Load radius
B: Load point height
C: Lifting capacity

Rating over-side or 360 degrees Rating over-rear

EX100WD-3 with Off-set front (Equipped with rear outriggers on ground)

Unit: 1 000 kg (1 000 lb)

Conditions	Load point height m (ft in)	Load radius										At max. reach						
		2 (6'7")		3 (9'10")		4 (13'1")		5 (16'5")		6 (19'8")		7 (23'0")				m (ft in)		
Arm 1.96 m (6'5") Bucket PCSA: 0.46 m ³ (0.60 cu yd) CECE: 0.40 m ³ Tires 9.00-20-12PR, duals	5 (16'5")							*1.91 (4.21)	*1.91 (4.21)							*0.77 (1.70)	*0.77 (1.70)	6.38 (20'11")
	4 (13'1")					*2.15 (4.74)	*2.15 (4.74)	*2.06 (4.54)	*2.06 (4.54)							*0.74 (1.63)	*0.74 (1.63)	6.87 (22'6")
	3 (9'10")			*3.73 (8.22)	*3.73 (8.22)	*2.75 (6.06)	*2.75 (6.06)	*2.36 (5.20)	*2.36 (5.20)	1.75 (3.86)	*2.24 (4.94)					*0.74 (1.63)	*0.74 (1.63)	7.16 (23'6")
	2 (6'7")					3.38 (7.45)	*3.42 (7.54)	2.33 (5.14)	*2.73 (6.02)	1.69 (3.73)	*2.42 (5.34)					*0.76 (1.68)	*0.76 (1.68)	7.28 (23'11")
	1 (3'3")					3.16 (6.97)	*3.98 (8.78)	2.21 (4.87)	*3.08 (6.79)	1.62 (3.57)	2.55 (5.62)					*0.80 (1.76)	*0.80 (1.76)	7.23 (23'9")
	0 (Ground)			4.99 (11.0)	*6.20 (13.7)	3.05 (6.73)	*4.33 (9.55)	2.13 (4.70)	*3.34 (7.36)	1.59 (3.51)	2.51 (5.53)					*0.87 (1.92)	*0.87 (1.92)	7.03 (23'1")
	-1 (-3'3")	*4.97 (11.0)	*4.97 (11.0)	4.99 (11.0)	*6.20 (13.7)	3.01 (6.64)	*4.48 (9.88)	2.11 (4.65)	3.36 (7.41)							*0.99 (2.18)	*0.99 (2.18)	6.63 (21'9")
	-2 (-6'7")	*8.23 (18.1)	*8.23 (18.1)	5.07 (11.2)	*5.93 (13.1)	3.06 (6.75)	*4.36 (9.61)	2.16 (4.76)	*3.30 (7.28)							*1.18 (2.60)	*1.18 (2.60)	6.01 (19'9")
	-3 (-9'10")	*7.57 (16.7)	*7.57 (16.7)	*5.24 (11.6)	*5.24 (11.6)	3.23 (7.12)	*3.74 (8.25)									*1.55 (3.42)	*1.55 (3.42)	5.06 (16'7")

- Notes: 1. Ratings are based on SAE J1097.
2. Lifting capacity of the Super EX Series does not exceed 75% of tipping load with the machine on firm, level ground or 87% of full hydraulic capacity.
3. The load point is a hook (not standard equipment) loaded on the back of the bucket.
4. *Indicates load limited by hydraulic capacity.

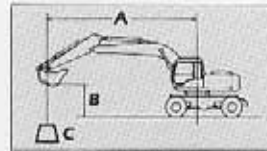

A: Load radius
B: Load point height
C: Lifting capacity

ENGLISH MEASURE

EX100WD-3 (Not equipped with rear outriggers)

Rating over-side or 360 degrees Rating over-rear Unit: 1 000 lb

Conditions	Load point height ft in	Load radius										At max. reach					
		5'0"		10'0"		15'0"		20'0"		ft in							
														@ft in			
Boom 14'0" Arm 6'5" Bucket PCSA: 0.60 yd ³ Tires 9.00-20-12PR, duals	15'0"					4.61	5.53								*2.59	*2.59	21'0"
	10'0"			8.41	10.11	4.33	5.25								2.18	*2.58	22'8"
	5'0"			7.49	9.17	4.01	4.92	2.46	3.08						2.02	2.53	23'3"
	0 (Ground)			7.24	8.91	3.81	4.72								2.11	2.65	22'4"
	-5'0"	*12.64	*12.64	7.26	8.93	3.80	4.71								2.55	3.17	20'1"
	-10'0"			7.59	9.24										4.04	4.92	15'5"
Boom 14'0" Arm 7'5" Bucket PCSA: 0.60 yd ³ Tires 9.00-20-12PR, duals	15'0"					4.64	5.56								*2.21	*2.21	22'0"
	10'0"			8.54	*9.83	4.34	5.25	2.54	3.17						1.98	*2.20	23'8"
	5'0"			7.49	9.17	3.97	4.88	2.42	3.04						1.83	2.32	24'2"
	0 (Ground)			7.10	8.27	3.73	4.64	2.33	2.95						1.90	2.41	23'3"
	-5'0"	*11.41	*11.41	7.08	8.75	3.69	4.59								2.26	2.85	21'1"
	-10'0"			7.37	9.04										3.41	4.19	16'9"

- Notes: 1. Ratings are based on SAE J1097.
 2. Lifting capacity of the Super EX Series does not exceed 75% of tipping load with the machine on firm, level ground or 87% of full hydraulic capacity.
 3. The load point is a hook (not standard equipment) loaded on the back of the bucket.
 4. *Indicates load limited by hydraulic capacity.

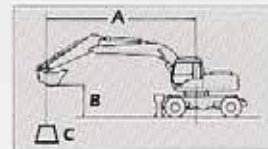

A: Load radius
B: Load point height
C: Lifting capacity

ENGLISH MEASURE

EX100WD-3 (with rear outriggers on ground)

Rating over-side or 360 degrees Rating over-rear Unit: 1 000 lb

Conditions	Load point height ft in	Load radius												At max. reach		
		5'0"		10'0"		15'0"		20'0"						@ft in		
Boom 14'0" Arm 6'5" Bucket PCSA: 0.60 yd ³ Tires 9.00-20-12PR, duals	15'0"					*6.38	*6.38							*2.59	*2.59	21'0"
	10'0"			*10.83	*10.83	6.66	*7.52							*2.58	*2.58	22'8"
	5'0"			12.26	*14.45	6.31	*8.88	3.96	*5.76					*2.74	*2.74	23'3"
	0 (Ground)			11.97	*15.02	6.10	*9.52							*3.11	*3.11	22'4"
	-5'0"	*12.64	*12.64	11.99	*13.50	6.09	*8.80							*3.87	*3.87	20'1"
	-10'0"			*9.24	*9.24									*5.42	*5.42	15'5"
Boom 14'0" Arm 7'5" Bucket PCSA: 0.60 yd ³ Tires 9.00-20-12PR, duals	15'0"					*5.84	*5.84							*2.21	*2.21	22'0"
	10'0"			*9.83	*9.83	6.68	*7.05	4.05	*5.21					*2.20	*2.20	23'8"
	5'0"			12.28	*13.75	6.28	*8.52	3.91	6.54					*2.34	*2.34	24'2"
	0 (Ground)			11.83	*14.93	6.02	9.36	3.82	5.88					*2.66	*2.66	23'3"
	-5'0"	*11.41	*11.41	11.80	*13.86	5.97	*8.98							*3.31	*3.31	21'1"
	-10'0"			*10.36	*10.36									*4.91	*4.91	16'9"

- Notes: 1. Ratings are based on SAE J1097.
 2. Lifting capacity of the Super EX Series does not exceed 75% of tipping load with the machine on firm, level ground or 87% of full hydraulic capacity.
 3. The load point is a hook (not standard equipment) loaded on the back of the bucket.
 4. *Indicates load limited by hydraulic capacity.

ENGLISH MEASURE

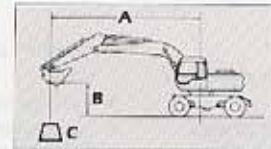

A: Load radius
B: Load point height
C: Lifting capacity

EX100WD-3 with Off-set front (Not equipped with rear outriggers) Rating over-side or 360 degrees Rating over-rear Unit: 1 000 lb

Conditions	Load point height ft in	Load radius												At max. reach				
		5'0"		10'0"		15'0"		20'0"										
																@ft in		
Arm 6'5" Bucket PCSA: 0.60 cu yd Tires 9.00-20-12PR, duals	15'0"					*4.22	*4.22									*1.66	*1.66	21'9"
	10'0"			*7.91	*7.91	3.99	4.92	2.18	2.81							*1.62	*1.62	23'6"
	5'0"					3.42	4.34	1.99	2.62							1.51	*1.70	23'8"
	0 (Ground)			5.93	7.61	3.07	3.99	1.86	2.49							1.55	*1.92	23'1"
	-5'0"	*12.2	*12.2	5.98	7.65	3.03	3.95									1.91	*2.38	20'10"
	-10'0"	*20.7	*20.7	6.48	8.17											3.13	*3.38	16'5"

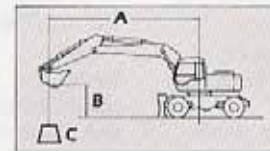

A: Load radius
B: Load point height
C: Lifting capacity

Rating over-side or 360 degrees Rating over-rear

EX100WD-3 with Off-set front (Equipped with rear outriggers on ground)

Unit: 1 000 lb

Conditions	Load point height ft in	Load radius												At max. reach				
		5'0"		10'0"		15'0"		20'0"										
																@ft in		
Arm 6'5" Bucket PCSA: 0.60 cu yd Tires 9.00-20-12PR, duals	15'0"					*4.22	*4.22									*1.66	*1.66	21'9"
	10'0"			*7.91	*7.91	3.99	*5.44	2.18	*4.78							*1.62	*1.62	23'6"
	5'0"					3.42	*7.01	1.99	*5.51							1.51	*1.70	23'8"
	0 (Ground)			5.93	*13.4	3.07	*8.15	1.86	*3.88							1.55	*1.92	23'1"
	-5'0"	*12.2	*12.2	5.98	*13.2	3.03	*8.42									1.91	*2.38	20'10"
	-10'0"	*20.7	*20.7	6.48	*11.3											3.13	*3.48	16'5"

- Notes: 1. Ratings are based on SAE J1097.
2. Lifting capacity of the Super EX Series does not exceed 75% of tipping load with the machine on firm, level ground or 87% of full hydraulic capacity.
3. The load point is a hook (not standard equipment) loaded on the back of the bucket.
4. *Indicates load limited by hydraulic capacity.



STANDARD EQUIPMENT

Standard equipment may vary by country, so please consult your Hitachi dealer for details.

ENGINE

- 30 A alternator
- Dry-type air filter with evacuator valve
- Cartridge-type engine oil filter
- Cartridge-type engine oil bypass filter
- Cartridge type fuel filter
- Radiator and oil cooler with dust protective net
- Radiator reserve tank
- Fan guard
- Isolation-mounted engine
- Auto-idling system

HYDRAULIC SYSTEM

- Load-sensing system
- Flow dividing control system
- Work mode selector
- Engine speed sensing system
- E-P control system (power mode selector)
- Hydraulic warm-up control system for hydraulic oil
- Quick warm-up system for pilot circuit
- Shockless valve in pilot circuit
- Swing cushion valve in swing circuit
- Brake valves for travel circuits
- Accumulator in pilot circuit

- Control valve with main relief valve
- Extra port for control valve
- Suction filter
- Full-flow filter
- Pilot filter

CAB

All-weather sound-suppressed steel cab equipped with reinforced, tinted (bronze color) glass windows, openable front windows-upper with assist spring, and lower and both side windows with intermittent windshield wipers, front window washer, curved rear window, adjustable suspension seat with armrests, electric double horn, auto-tuning radio with digital clock, auto-idle switch, seat belt, cigarette lighter, ashtray, parcel pocket, rear tray, floor mat, heater, and pilot control shut-off lever.

MONITOR SYSTEM

Meters:
Tachometer, hourmeter, engine coolant temperature gauge, air pressure gauge, fuel meter.

- Warning lamps:
Alternator charge, engine oil pressure, engine overheat, engine oil filter clog, air cleaner clog, minimum fuel lever, air pressure.
- Pilot lamps:
Working light, engine oil level, engine coolant level, hydraulic oil level, engine pre-heat, turn signal, head light high beam, parking brake, digging brake, oscillation cylinder lock, hazard warning signal.
- Alarm buzzers:
Engine oil pressure, engine overheat, air pressure, back buzzers
- Swing lock for travel and transportation

LIGHTS AND SIGNALS

2 headlights (single-type), 1 working light, Combination lamps (turn signal lamps, parking lamps, brake lamps, marker lamps and hazard warning signal lamps).

UPPERSTRUCTURE

- Undercover
- 1 700 kg (3 750 lb) counterweight

- Fuel level gauge
- Hydraulic oil level gauge
- Utility space
- Rearview mirror
- Swing parking brake

UNDERCARRIAGE

- Travel parking brake
- Tool box
- Traction type pattern tires 9.00-20-12PR

FRONT ATTACHMENTS

- Bucket clearance adjust mechanism
- Monolithically cast bucket link A
- Centralized lubrication system
- Dirt seals on all bucket pins
- 2.26 m (7'5") arm
- 0.46 m³ (0.60 yd³: PCSA heaped) bucket

MISCELLANEOUS

- Standard tool kit
- Lockable machine covers
- Lockable fuel filling cap
- Skid-resistant tapes and handrails.



OPTIONAL EQUIPMENT

Optional equipment may vary by country, so please consult your Hitachi dealer for details.

- Air conditioner
- Fenders for tires
- Rear outrigger
- Rear dozer blade [width: 2 470 mm (8'1"), height: 580 mm (1'11")]
- Heavyduty type pattern tires 9.00-20-12PR
- Multi selection lever with rotary valve
- Off-set front
- Electric fuel refilling pump
- Back lamp and license plate lamp

- Fender mirror
- Piping kit for extra port
- PTO valve & Additional valve with piping kit
- V-shaped bucket for water-ways and drainage.
- Clamshell bucket for deep, vertical excavations like manholes, pilings, footings, etc.
- Slope-finishing blade for slope finishing jobs ... scraping up or down, compacting, leveling, grading etc.

Type of Bucket



V-shaped bucket

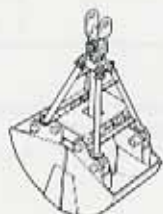

Clamshell bucket



Slope-finishing blade

Hitachi Construction Machinery Co., Ltd.

Head Office: Nippon Bldg., 6-2, 2-chome, Ohtemachi,
Chiyoda-ku, Tokyo 100, Japan

Telephone: Tokyo (03) 3245-6388

Facsimile: Tokyo (03) 3246-2609

Telex: J32539 HITACONJ

Cable Address: "TOKHITACHIKENKI"

KS-E110

These specifications are subject to change without notice. Illustrations and photos show the standard models, and may or may not include optional equipment, accessories, and all standard equipment, with some differences in color and features.

Printed in Japan KS-R [H,H] (GT3-S, KS-R)