

Mini-Excavator EX17U Specifications

Rated Engine Power	
DIN 6271, net	8.9 kW (12.1 PS)
SAE J1349, net	9.0 kW (12.1 hp)
Operating Weight	
Rubber shoes	1 740 kg (4-pillar canopy)
Backhoe Buckets	
ISO 7451	0.02 – 0.05 m ³

The 4-pillar canopy conforms to TOPS (ISO 12117) and FOPS (ISO 10262, Level I) requirements.

■ DIMENSIONS

Unit : mm

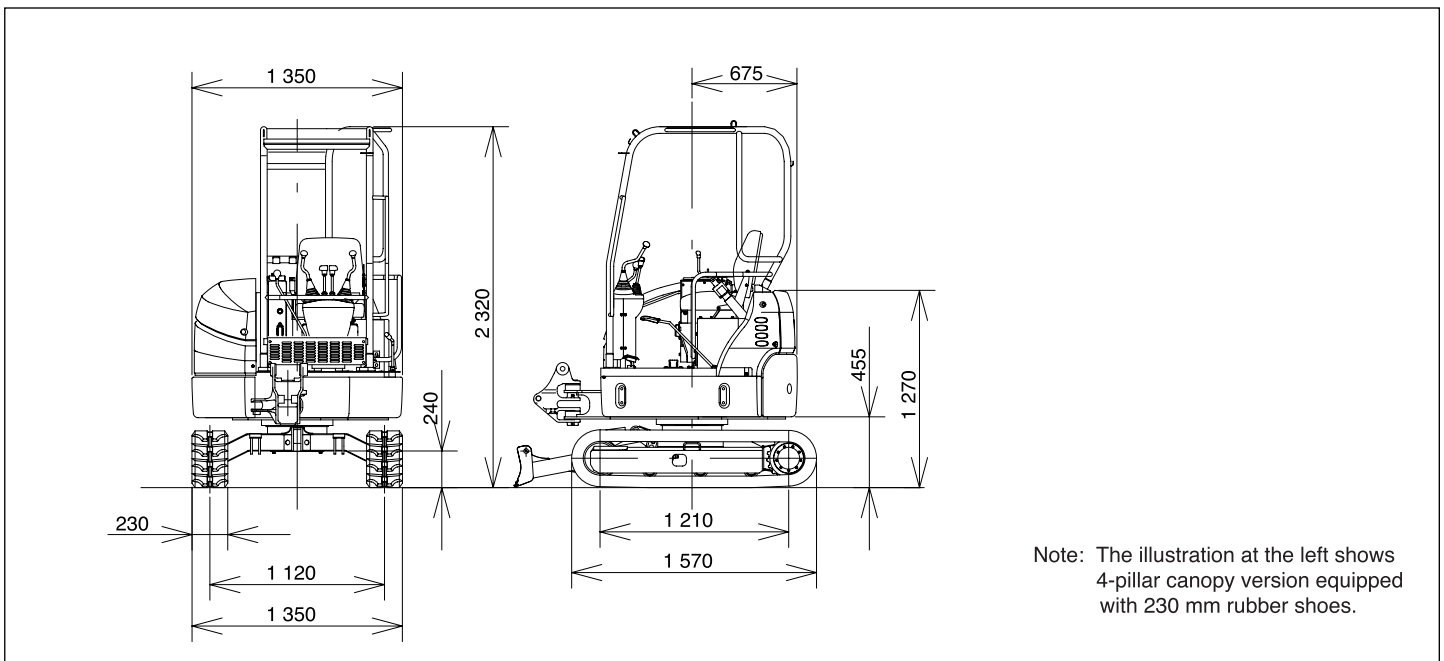

■ WORKING RANGES

Unit : mm

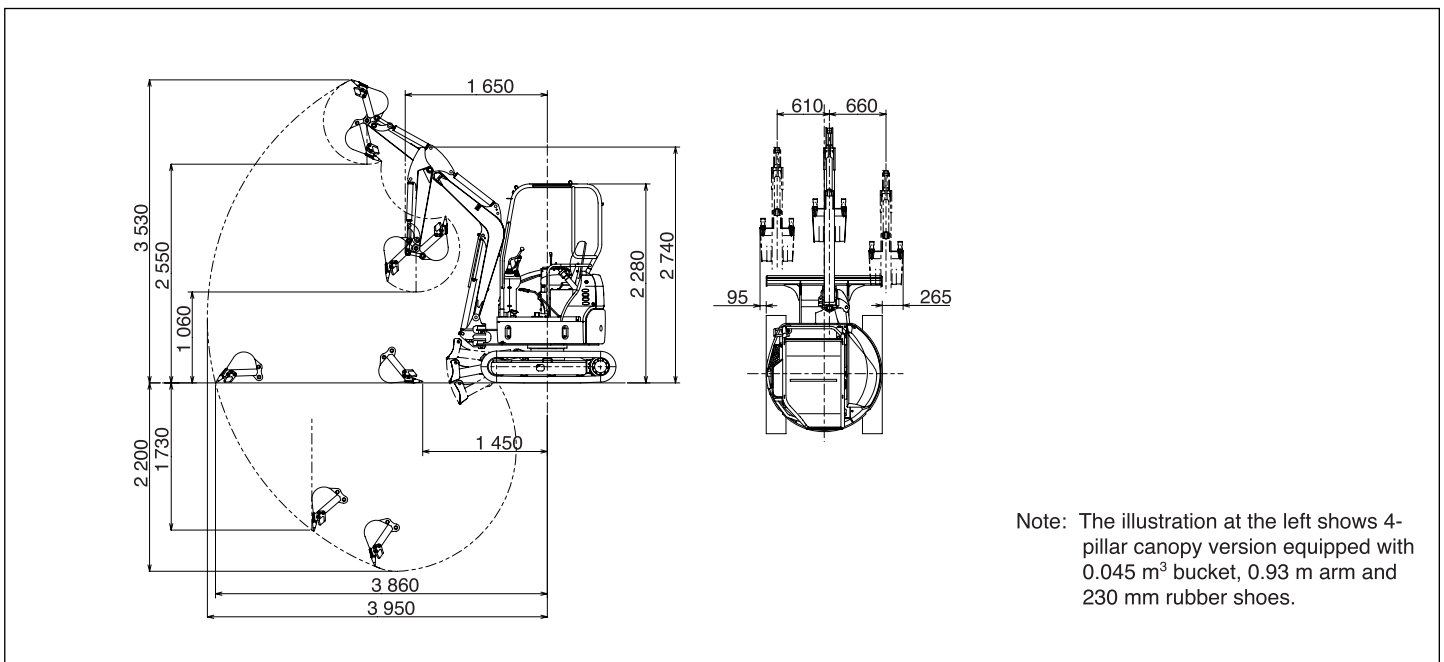



ENGINE

Model.....Isuzu 3YB1
 Type.....Water-cooled, 4-cycle, 3-cylinder swirl chamber type diesel engine
 Rated power.....8.9 kW (12.1 PS)
 DIN 6271, net at 2 300 min⁻¹ (rpm)
 Rated power.....9.0 kW (12.1 hp)
 SAE J1349, net at 2 300 min⁻¹ (rpm)
 Maximum torque.....40.5 N·m (4.0 kgf·m)
 at 1 700 min⁻¹ (rpm)
 Piston displacement.....0.761 L
 Bore and stroke.....67 mm x 72 mm
 Battery.....1 x 12 V, 55 Ah



HYDRAULIC SYSTEM

The Optimum Hydraulic System (OHS) uses three pumps for job efficiency and smooth combined operations.

Main pumps.....Two variable displacement axial piston pumps
 Maximum oil flow..... 2 x 16.8 L/min
 Third pump.....One gear pump
 Maximum oil flow.....12.5 L/min
 Pilot pump.....One gear pump
 Maximum oil flow..... 6.5 L/min

Relief Valve Settings

Implement circuit.....20.6 MPa (210 kgf/cm²)
 Swing circuit.....18.6 MPa (190 kgf/cm²)
 Travel circuit.....20.6 MPa (210 kgf/cm²)
 Pilot circuit.....3.9 MPa (40 kgf/cm²)

Hydraulic Cylinders

High-strength piston rods and tubes. Cylinder cushion mechanisms provided in boom raise, arm roll-in and roll-out circuits to absorb shocks at stroke ends.

Dimensions

	No.	Bore	Rod dia.	Stroke
Boom.....	1	55 mm	30 mm	455 mm
Arm.....	1	55 mm	30 mm	420 mm
Bucket.....	1	50 mm	30 mm	315 mm
Boom swing... 1	60 mm	30 mm	373 mm	
Blade.....	1	60 mm	35 mm	100 mm



CONTROLS

Hydraulic pilot control levers for boom, arm, bucket, swing and travel. Mechanical linkage control levers for boom swing and blade.



SWING MECHANISM

High-torque, axial piston motor with planetary reduction gear. Swing circle is single-row, shear-type ball bearing with induction-hardened internal gear. Internal gear and pinion are immersed in lubricant. Swing parking brake is spring-set/hydraulic-released disc type. Swing shockless valve built in swing motor absorbs shocks when stopping swing, ensuring smooth stops.

Swing speed..... 8.6 min⁻¹ (8.6 rpm)



UNDERCARRIAGE

Tracks

Tractor-type undercarriage. Welded track frame using carefully selected materials. Side frame welded to track frame.

Numbers of Rollers on Each Side

Lower rollers.....3

Traction Device

Each track driven by a high-torque, 2-speed axial piston motor through planetary reduction gear, allowing counter-rotation of the tracks. Travel shockless relief valve built in travel motor absorbs shocks when stopping travel, ensuring smooth stops.

Travel speeds (rubber shoes)..... High : 0 – 4.0 km/h
 Low : 0 – 2.0 km/h

Gradeability.....30 degrees (58%) continuous



WEIGHTS AND GROUND PRESSURE

Equipped with 0.93 m arm and 0.045 m³ (ISO 7451 heaped) bucket

	Operating weight	Ground pressure
230 mm rubber shoes....	1 730 kg	27 kPa (0.27 kgf/cm ²)



FRONT-END ATTACHMENTS

Backhoe Buckets

ISO 7451 capacity	Width		No. of teeth	Weight	Use	
	Without side cutters	With side cutters			0.93 m Std. arm	1.13 m Long arm
0.02 m ³	200 mm	250 mm	2	25 kg	A	A
0.035 m ³	300 mm	350 mm	3	30 kg	A	A
0.04 m ³	350 mm	400 mm	3	32 kg	A	A
0.045 m ³	400 mm	450 mm	3	33 kg	A	B
0.05 m ³	450 mm	500 mm	4	36 kg	B	C
Arm crowd force					9.0 kN (910 kgf)	8.0 kN (820 kgf)
Bucket digging force					13.5 kN (1 380 kgf)	

A: General digging
 B: Light-duty digging
 C: Loading

Boom swing angle.....Left 65°, Right 50°



STANDARD EQUIPMENT

Engine

• Water-separator for engine fuel system

Hydraulic System

- Hydraulic pilot type control levers for boom, arm, bucket, swing and travel
- Mechanical linkage type control levers for boom swing and blade
- Pilot control shut-off levers for boom, arm, bucket, swing and travel
- Two-speed travel system
- Swing parking brake

Operator's Room

- 4-pillar canopy
- Work lamp
- Seat belt
- 12V outlet

Undercarriage

- 230 mm rubber shoes
- Semi-long stay blade

Front Attachments

- 1.8 m boom
- 0.93 m arm
- 0.045 m³ hoe bucket
- Bucket clearance adjusting device
- O-ring type pin-seals for hoe bucket
- HN bushing

LIFTING CAPACITIES

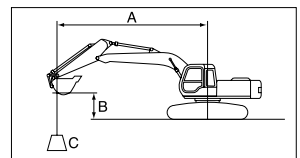

A: Load radius
 B: Load point height
 C: Lifting capacity

Rating over-side or 360 degrees Rating over-front Unit: 1 000 kg

With blade above ground

Conditions	Load Point Height	Load Radius						Maximum Reach		
		1 m		2 m		3 m		meter		
Arm: 0.93 m Bucket: 0.045 m ³ ISO 7451 Rubber shoes: 230 mm	2 m							0.18	0.17	3.58
	1 m							0.16	0.15	3.81
	Ground			0.41	0.39	0.22	0.21	0.17	0.16	3.63
	- 1 m	*1.04	*1.04	0.41	0.39	0.22	0.21	0.23	0.23	2.95

With blade on ground

Conditions	Load Point Height	Load Radius						Maximum Reach		
		1 m		2 m		3 m		meter		
Arm: 0.93 m Bucket: 0.045 m ³ ISO 7451 Rubber shoes: 230 mm	2 m							0.18	*0.26	3.58
	1 m							0.16	*0.27	3.81
	Ground			0.41	*0.77	0.22	*0.39	0.17	*0.29	3.63
	- 1 m	*1.04	*1.60	0.41	*0.62	0.22	*0.34	0.23	*0.28	2.95

Notes: 1. Rating are based on ISO 10567.
 2. Lifting capacity does not exceed 75% of tipping load with the machine on firm, level ground or 87% full hydraulic capacity.

3. The load point is a hook (not standard equipment) located on the back of the bucket.
 4. An asterisk mark (*) indicates load limited by hydraulic capacity.

 **Hitachi Construction Machinery Co., Ltd.**

Head office: 5-1 Koraku 2-chome, Bunkyo-ku
Tokyo 112-8563, Japan

Telephone: (03)3830-8050

Facsimile: (03)3830-8204

This catalog is not applicable to European and North America areas.
Specifications are subject to change without notice.

KS-E469

Printed in Japan 06.06 (SO/SO, HT3)